

# GASKET



## Product guide

Spiral wound gasket		P3 to P7
PILAFLO <sup>TM</sup> filler spiral wound gasket	No.2300(No.2300S)	P5
PILLARFOIL <sup>TM</sup> filler spiral wound gasket	No.2600(No.2600N)	P5
Deadline thickness adjustment type spiral wound gasket	No.2620	P6
Low tightening pressure and high airtight type spiral wound gasket	No.2600LT	P6
Low tightening pressure and high airtight type spiral wound gasket for cryogenic applications	No.2600LTL	P6
Spiral wound gasket	No.2500	P7
Spiral wound gasket for high temperature applications	No.2700	P7
Joint soft cut gasket		P8
Technograph <sup>TM</sup> Sheet (Non-asbestos jointing sheet)	No.5600(No.5600N)	P8
General-purpose non-asbestos jointing sheet	No.5650, 5611	P8
PILLARFOIL <sup>TM</sup> soft cut gasket		P9
PILLARFOIL <sup>TM</sup> soft cut gasket	No.6630(No.6630N)	P9
PILLARFOIL <sup>TM</sup> soft cut gasket with a metal plate	No.6631	P9
Metal foil inserted PILLARFOIL <sup>TM</sup> soft cut gasket	No.6633(No.6633N)	P9
Rubber sheet gasket		P10
Rubber sheet gasket	No.5001	P10
Rubber sheet gasket with fiber cloth	No.5002	P10
High-strength rubber sheet gasket with aramid fiber	No.5003-NBR	P10
Low-tightening pressure general-purpose thin type gasket	No.2502LT-EOS	P11
Corrugated metal gasket coated with flexible graphite	No.1200G-H	P11
Inorganic sheet gasket for high temperature gas	No.9900-T	P11
PILLARFOIL <sup>TM</sup> tape		P12
PILLARFOIL <sup>TM</sup> Plain-Tape	No.6660	P12
PILLARFOIL <sup>TM</sup> Crinkle-Tape	No.6670	P12
Expanded PTFE gasket / Sanitary gasket / Sanitary tube		P13 to P15
Expanded PTFE joint sealant	No.3300, 3300-F	P13
Expanded PTFE flat joint sealant	No.3330	P13
Expanded PTFE hyper sheet gasket	No.3350	P14
Expanded PTFE hyper clean sheet gasket	No.3355	P14
Expanded PTFE sanitary ferrule gasket	No.3356	P15
Sanitary union gasket made of fluorocarbon polymers	No.3356-U	P15
Sanitary PFA tube	No.8881	P15
Low-creep PTFE sheet gasket	No.4001/No.4002/No.4003	P16
PILAFLO <sup>TM</sup> PTFE envelope gasket	No.4410 series	P17
PILAFLO <sup>TM</sup> solid gasket	No.4400/No.4401	P18
Metallic gasket		P19 to P26
Corrugated metal gasket	No.1200	P21
Grooved gasket	No.1300	P21
Plain metal gasket	No.1400	P21
Octagonal ring joint gasket	No.1500	P22
Oval ring joint gasket	No.1501	P23
Pressure seal ring gasket	No.1502	P24
Lens ring gasket	No.1503	P25
Delta ring gasket	No.1504	P25
Metal hollow O-ring	No.1700/No.1701/No.1702	P26

## Product guide

Metal jacketed gasket		P27 to P30
Metal jacketed gasket (Flat, double jacketed)	No. 1 050	P29
Metal jacketed gasket (Flat, double shell)	No. 1 054	P29
Metal jacketed gasket (Corrugated, double jacketed)	No. 1 056	P29
Metal jacketed gasket (Round)	No. 1 150	P30
Metal jacketed gasket with PILLARFOIL™ adhered (Flat, double jacketed)	No. 1 650	P30
Metal jacketed gasket with PILLARFOIL™ adhered (Flat, double shell)	No. 1 654	P30
PILLARFOIL™ pressure seal ring gasket	No. 6690	P31
PILLARFOIL™ yarn braided packing for dresser joints	No. 6815DJ	P32
Gasket cutter set	No. 1 801	P33

## Size tables

Spiral wound gasket	Spiral wound gaskets for JIS 16K to JIS 63K pipe flanges (basic type/with inner ring)	P34
Spiral wound gasket	Spiral wound gasket for JIS-rated pipe flanges (with outer ring)	P35
Spiral wound gasket	Spiral wound gasket for JIS-rated pipe flanges (with inner and outer rings)	P36
Spiral wound gasket	Spiral wound gasket for JIS 10K to 20K large-diameter flanges (with inner and outer rings)	P37
Spiral wound gasket	Spiral wound gaskets for ANSI (JPI) pipe flanges (basic type/with inner ring) For Classes 300 to 2500, flange sizes up to 600A (24B) , and flanges with unified threads or metric threads	P38
Spiral wound gasket	Spiral wound gaskets for ANSI (JPI) pipe flanges (with outer ring/with inner and outer rings) For Classes 150 to 600, flange sizes up to 600A (24B), and flanges with unified threads	P39
Spiral wound gasket	Spiral wound gaskets for ANSI (JPI) pipe flanges (with outer ring/with inner and outer rings) For Classes 900 to 2500, flange sizes up to 600A (24B), and flanges with unified threads	P40
Spiral wound gasket	Spiral wound gaskets for ANSI (JPI) Series A pipe flanges (with outer ring/with inner and outer rings) For Classes 150 to 900, flange sizes 650 to 1500A (26 to 60B), and flanges with unified threads	P41
Spiral wound gasket	Spiral wound gaskets for ANSI (JPI) Series B pipe flanges (with outer ring/with inner and outer rings) For Classes 150 to 900, flange sizes 650 to 1500A (26 to 60B), and flanges with unified threads	P42
Ring joint gasket	Ring joint gaskets for JPI, API, ANSI, and MSS pipe flanges	P43 and P44
Ring joint gasket	Ring joint gasket for API pipe flanges (BX cross-section type)	P45
Ring joint gasket	Ring joint gasket for API pipe flanges (RX cross-section type)	P46
Soft gasket	Soft gaskets for JIS-rated pipe flanges (for flat face flanges, large raised face flanges, small raised face flanges, male-female flanges, and tongue and groove flanges)	P47
Soft gasket	Soft gasket for JIS-rated pipe flanges For flat face (FF) flanges	P48
Soft gasket	Soft gasket for ANSI (JPI) pipe flanges For raised face (RF) flanges	P49
Soft gasket	Soft gasket for ANSI (JPI) pipe flanges For Series A and Series B raised face flanges (Group I)	P50
Soft gasket	Soft gasket for ANSI (JPI) pipe flanges For flat face (FF) flanges	P51
Soft gasket	Soft gasket for ANSI (JPI) pipe flanges For flat face (FF) flanges (Series A)	P52
Soft gasket	Soft gasket for ANSI (JPI) pipe flanges For flat face (FF) flanges (Series B)	P53
Soft gasket	Soft gasket for JPI male-female flanges and tongue and groove flanges	P54
PILAFLON™ jacketed gasket	PILAFLON™ jacketed gaskets for JIS-rated pipe flanges with nominal pressure 5K/10K	P55 and P56
PILAFLON™ jacketed gasket	PILAFLON™ jacketed gaskets for JIS-rated pipe flanges with nominal pressure 16K/20K/30K	P57 and P58
PILAFLON™ jacketed gasket	PILAFLON™ jacketed gaskets for ANSI (JPI) Class 75/150 pipe flanges	P59 and P60
PILAFLON™ jacketed gasket	PILAFLON™ jacketed gaskets for ANSI (JPI) Class 300 pipe flanges	P61 and P62

**Figure 1: Water-based fluids** (Typical fluids) Water, seawater, warm water, hot water, water vapor, superheated steam, etc.

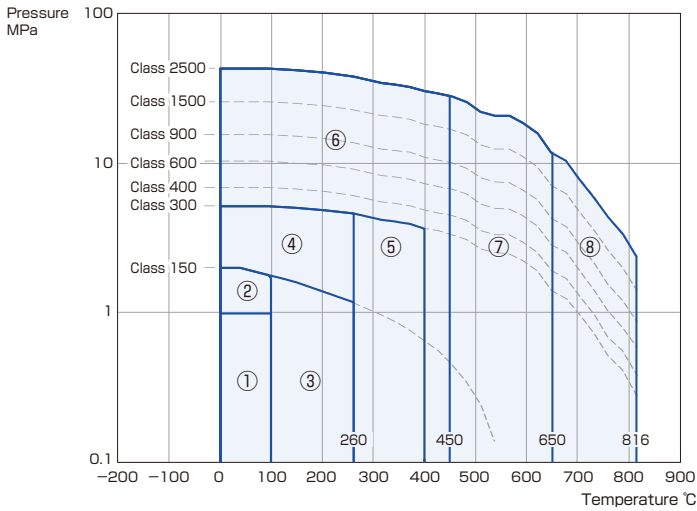

Area number	Applicable product numbers		
	1st recommendation	2nd recommendation	3rd recommendation
①	<u>No.5600, No.5650, No.5611</u> *1	<u>No.5001, No.5002</u>	<u>No.6633, No.6631</u>
②	<u>No.5600, No.5650, No.5611</u> *1	No.5003-NBR	<u>No.6633, No.6631</u>
③	No.2600 series	<u>No.6633, No.6631</u>	No.5600 *2
④	No.2600 series	<u>No.6633, No.6631</u>	No.1500 series
⑤	No.2600 series	<u>No.6633, No.6631</u>	No.1500 series
⑥	No.2600 series	No.1500 series	—
⑦	No.1500 series	No.2700 series	—
⑧	No.1500 series	—	—

Notes: 1) The underlined gasket product numbers in the table are recommended in particular.  
 2) Use of flexible graphite products (No. 6633, No. 6631, and No. 2600 series) for seawater and steam produced from seawater is not recommended.  
 \*1: The thicknesses of No. 5600, No. 5650, and No. 5611 gaskets are no more than 2.0 mm.  
 \*2: The usage range in high-temperature areas is limited. (Up to 214°C is recommended.)

**Figure 2: Oil-based fluids** (Typical fluids) Crude oil, volatile oil, naphtha, kerosene, diesel fuel, heavy oil, LPG, alcohol, furfural, ethylene glycol, ethylene, propylene, B-B fraction, butadiene, liquid ammonia, phenol, acrylonitrile, acetone, acetaldehyde, benzene, toluene, xylene, ethylbenzene, cyclohexane, tetramethylene sulfone, etc.

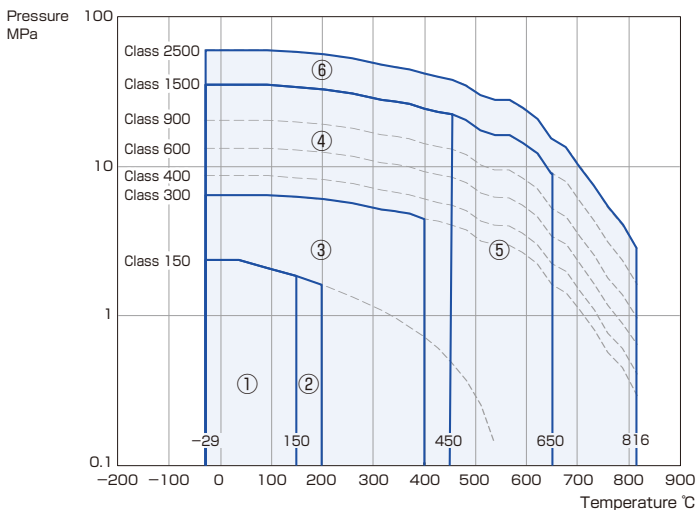

Area number	Applicable product numbers		
	1st recommendation	2nd recommendation	3rd recommendation
①	<u>No.6633, No.6631</u>	No.4001, No.4002, No.4003 *3	<u>No.5600, No.5650</u> *1 *2
②	<u>No.6633, No.6631</u>	No.2600 series	No.4001, No.4002, No.4003 *3
③	No.2600 series	<u>No.6633, No.6631</u>	No.1500 series
④	No.2600 series	No.1500 series	—
⑤	No.1500 series	No.2700 series	—
⑥	No.1500 series	—	—

Note: The underlined gasket product numbers in the table are recommended in particular.  
 \*1: The thicknesses of No. 5600 and No. 5650 gaskets are no more than 2.0 mm.  
 \*2: Use of No. 5600 and No. 5650 gaskets for the following highly toxic fluids and solvents is not recommended.  
 [Fluid examples]  
 Benzene, toluene, xylene, acetone, ethylbenzene, acetaldehyde, cyclohexane, tetramethylene sulfone, ethylene glycol, phenol, acrylonitrile, liquid ammonia, vinyl chloride monomer, diisopropanolamine, MEK, etc.  
 \*3: Use of No. 4001, No. 4002, and No. 4003 gaskets for monomers (vinyl chloride, styrene, butadiene, etc.) is not recommended.

**Figure 3: Corrosive fluids** (Typical fluids) Acids such as mineral acids, organic acids, mixed acids, and acidic solutions and alkalis

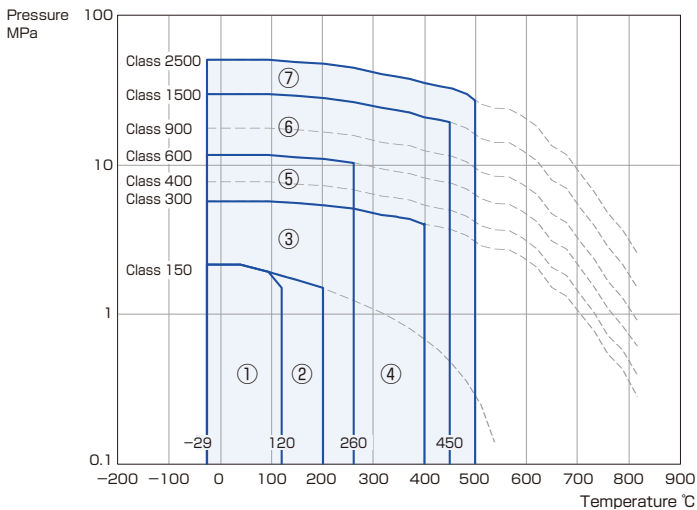

Area number	Applicable product numbers		
	1st recommendation	2nd recommendation	3rd recommendation
①	<u>No.4430, No.4410, No.4420</u> *1	No.4001, No.4002, No.4003	<u>No.6633, No.6631</u> *2
②	<u>No.2300 series, No.2600 series</u> *2	<u>No.6633, No.6631</u> *2	No.4001, No.4002, No.4003
③	<u>No.2300 series, No.2600 series</u> *2	<u>No.6633, No.6631</u> *2	No.1500 series
④	No.2600 series *2	<u>No.6633, No.6631</u> *2	No.1500 series
⑤	<u>No.2300 series, No.2600 series</u> *2	No.1500 series	—
⑥	No.1500 series	No.2600 series *2	—
⑦	No.1500 series	—	—

Note: The underlined gasket product numbers in the table are recommended in particular.  
 \*1: Some types of fluid may penetrate through the PTFE coating material to the inside of the gasket. In particular, nitric acid, ethylene oxide, halogen (such as chlorine and bromine), molten sulfur, monochloroacetic acid, and other similar fluids have strong osmosis. Care must be taken, therefore, when these fluids are used over a long period of time.  
 \*2: In principle, No. 6631, No. 6633, and No. 2600 series gaskets cannot be used in the following oxidizing acids and oxidizing salts.  
 [Fluid examples]  
 Oxidizing acids: Concentrated sulfuric acid, nitric acid, chromic acid, dichromic acid, mixed acids, etc.  
 Oxidizing salts: Calcium chlorate, calcium hypochlorite, sodium chlorite, sodium hypochlorite, etc.

**Figure 4: Gas-based fluid I** (Typical fluids) Air and nitrogen gas

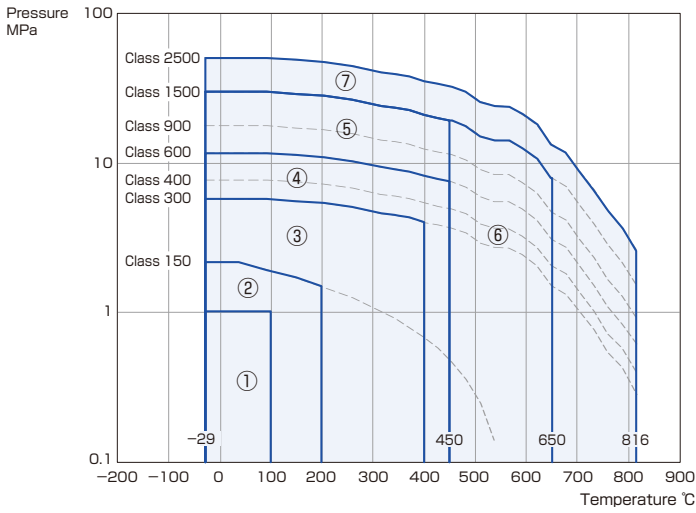

Area number	Applicable product numbers		
	1st recommendation	2nd recommendation	3rd recommendation
①	<u>No.5600</u> , No.5650 *1	No.5001	<u>No.6633</u> , No.6631
②	No.2600 series	<u>No.6633</u> , No.6631	—
③	No.2600 series	No.1500 series	<u>No.6633</u> , No.6631
④	No.2600 series	No.1500 series	—
⑤	No.1500 series	No.2600 series	—
⑥	No.1500 series	No.2700 series	—
⑦	No.1500 series	—	—

Note: The underlined gasket product numbers in the table are recommended in particular.  
 \*1: The thicknesses of No. 5600 and No. 5650 gaskets are no more than 2.0 mm and inner cross-sectional surfaces are coated with gasket paste.

**Figure 5: Gas-based fluid II** (Typical fluids) Flammable gases, combustion-supporting gases including oxygen, nonflammable gases, toxic gases, and other gases other than gas-based fluid I

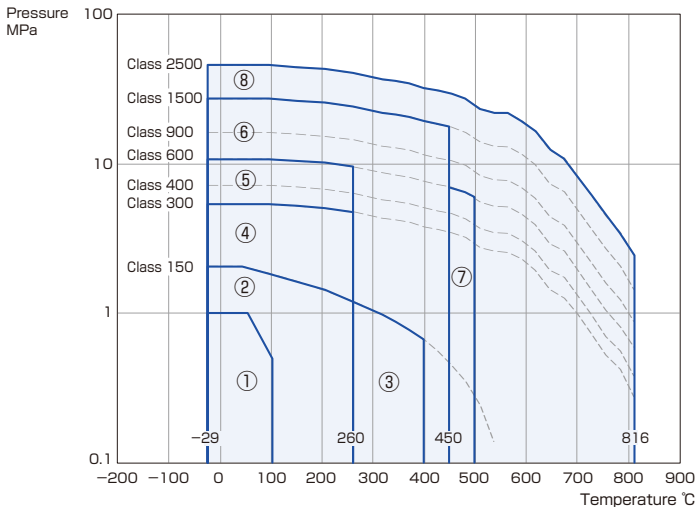

Area number	Applicable product numbers		
	1st recommendation	2nd recommendation	3rd recommendation
①	<u>No.2600 series *1*2</u> , No.2300 series	No.6633, No.6631 *1*2	No.5001 *1
②	<u>No.2600 series *1*2</u> , No.2300 series	No.6633, No.6631 *1*2	—
③	No.2600 series *1*2	<u>No.6633</u> , No.6631 *1*2	—
④	<u>No.2600 series *1*2</u> , No.2300 series	No.1500 series	—
⑤	<u>No.2600 series *1*2</u> , No.2300 series	No.1500 series	—
⑥	No.1500 series	No.2600 series *1*2	—
⑦	No.1500 series	No.2700 series *1*2	—
⑧	No.1500 series	—	—

Note: The underlined gasket product numbers in the table are recommended in particular.  
 \*1: Use of No. 5001, No. 6631, No. 6633, No. 2600 series, and No. 2700 series gaskets for combustion-supporting gases (including oxygen gas) and toxic gases is not recommended.  
 \*2: In principle, No. 6631, No. 6633, No. 2600 series, and No. 2700 series gaskets cannot be used for some halogen compounds (bromine, fluorine, iodine, chlorine dioxide, etc.).

**Figure 6: Low-temperature fluids** (Typical fluids) Arsine, diborane, hydroiodic acid, hydrogen chloride, liquid ammonia, chlorine, propane, propylene, LPG, acetylene, ethane, liquefied ethylene, LNG, liquid oxygen, liquid air, liquid nitrogen, etc.

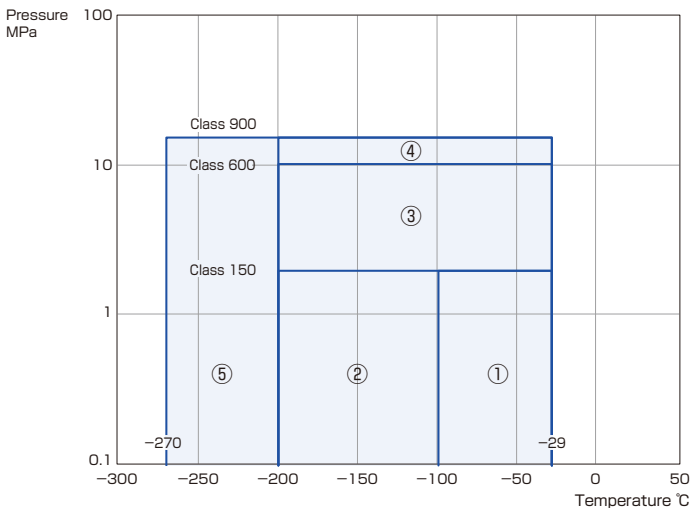

Area number	Applicable product numbers		
	1st recommendation	2nd recommendation	3rd recommendation
①	<u>No.6633</u> , No.6631	<u>No.2600LT series</u> , No.2600LTL series	No.2600 series, No.2300 series
②	No.2600LTL series	<u>No.2600 series</u> , No.2300 series	<u>No.6633</u> , No.6631
③	No.2600LTL series	<u>No.2600 series</u> , No.2300 series	No.1500 series
④	No.2600LTL series	No.2600 series	No.1500 series
⑤	No.2600LTL series	No.2600 series	—

Note: The underlined gasket product numbers in the table are recommended in particular.

The spiral wound gasket is manufactured by superimposing a tape-shaped thin metallic plate molded with a V-shaped cross section (hoop) and a non-metallic material with cushioning characteristics and sealability (filler) and winding them in spiral form. The product lineup includes not only the standard spiral wound gaskets with a flexible graphite or PTFE filler, but also spiral wound gaskets optimized for a wide range of applications.

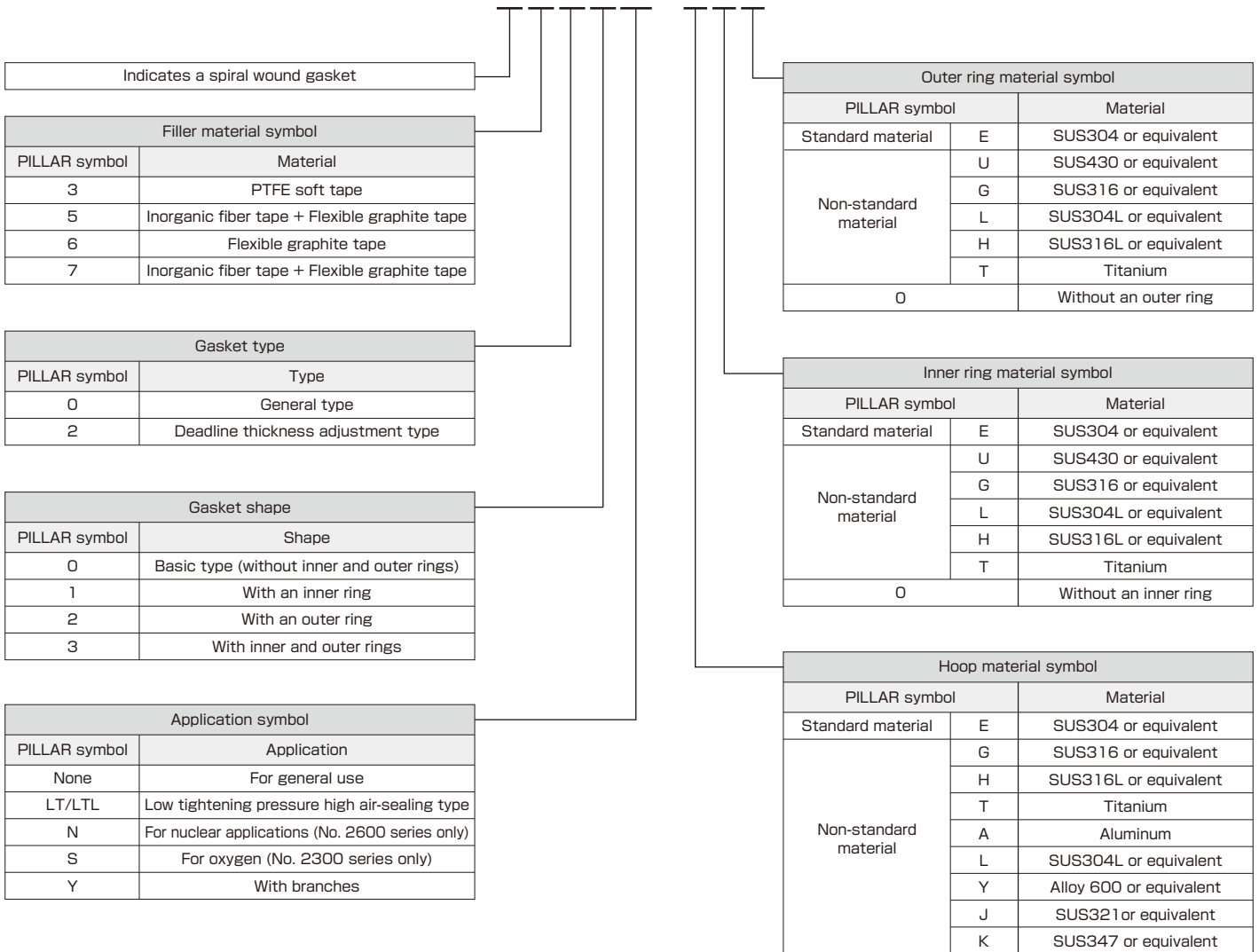

**Product number representation** | The product numbers of spiral wound gaskets are expressed as below.

## PILLAR No. 2603N - EEE

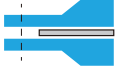
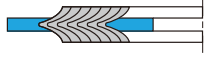

Note: For hoop materials, we continually maintain a stock of SUS304 or equivalent stainless steel and SUS316 or equivalent stainless steel. Other materials, however, may be difficult to obtain, so please consult with us in advance.

Flange shapes and recommended gasket shapes

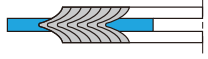
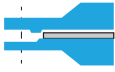
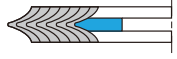
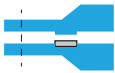
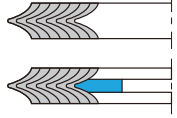
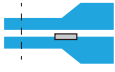
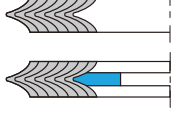
Flange shape		Recommended gasket shape	
Flat face flange		Gasket with inner and outer rings	
Raised face flange		Gasket with inner and outer rings	
Male-female flange		Gasket with an inner ring	
Tongue and groove flange		Basic type gasket Gasket with an inner ring	
Single spigot flange		Basic type gasket Gasket with an inner ring	

Permissible deviations on dimensions

(Unit: mm)

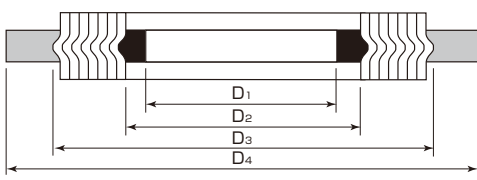
Dimension category	Main unit inside diameter $D_2$ and main unit outside diameter $D_3$ *1	Inner ring inside diameter $D_1$ and outer ring outside diameter $D_4$	
250 or less	$\pm 0.5$	$\pm 0.3$	
250 (not inclusive) to 630 (inclusive)	$\pm 0.8$	$\pm 0.5$	
630 (not inclusive) to 1600 (inclusive)	$\pm 1.3$	$\pm 0.8$	
Over 1600	$\pm 2.0$	$\pm 1.3$	

\*1:  $D_3$  does not apply to gaskets with an outer ring.

Permissible deviations on thickness

(Unit: mm)

Gasket body		Inner and outer rings	
Nominal thickness	Permissible deviations on dimensions	Nominal thickness	Permissible deviations on dimensions
4.8	$\pm 0.2$	3.0 (Stainless steel)	$\pm 0.25$
4.5	$+0.2$ 0	3.0 (Stainless steel)	$\pm 0.25$
3.2	$+0.2$ $-0.1$	2.0 (Stainless steel)	$\pm 0.2$

GASKET

No.2300 (No.2300S)

PILAFLON™ filler spiral wound gasket



This spiral wound gasket employs a chemical-resistant and highly flexible 100% PTFE soft tape as filler.

- This product is recommended for pipelines that require resistance to chemical agents, solvents, and other chemicals.
- The product lineup also includes the No. 2300S gasket, with materials degreased to prevent combustion-supporting gases such as oxygen and ozone from reacting to grease.

■ Specification conditions

Operating temperature range	Maximum operating pressure	Pressure class	Gasket factor ("m" value)	Minimum design seating stress ("y" value)	Minimum seating stress ("Y" value)
-200 to +260°C	15.5MPaG	Class 900 or lower	3	68.9N/mm <sup>2</sup>	39.2N/mm <sup>2</sup>

GASKET

No.2600 (No.2600N)

PILLARFOIL™ filler spiral wound gasket



This spiral wound gasket employs a flexible graphite tape as filler.

- This product provides excellent sealability, heat resistance, and chemical resistance.
- This product can be applied to a wide range of fluids.
- The product lineup also includes the No. 2600N gasket, which controls the chlorine ion concentration below 100 ppm.

■ Specification conditions

Operating temperature range	Maximum operating pressure	Pressure class	Gasket factor ("m" value)	Minimum design seating stress ("y" value)	Minimum seating stress ("Y" value)
-270 to 600°C*	43.1MPaG	Class 2500 or lower	3	68.9N/mm <sup>2</sup>	39.2N/mm <sup>2</sup>

\*When the gasket is used in an oxidizing atmosphere, the operating temperature must be no greater than 450°C.  
\*Operating temperature range of No. 2600N: -200 to 400°C



GASKET

No.2620

## Deadline thickness adjustment type spiral wound gasket



This spiral wound gasket employs a flexible graphite tape as filler.

- This gasket enables the seating stress to be adjusted when it is fastened to a specified thickness.

GASKET

No.2600LT

## Low tightening pressure and high airtight type spiral wound gasket



This spiral wound gasket provides excellent sealability even under low tightening pressure where specially treated flexible graphite tape is used as filler.

- This product is effective in preventing leakage of fluids (such as LPG) that gasify and cause slight leakage and effective in use with fluids that require strict sealability.
- This product can be used as improvement measures against sealability degradation caused by vibration difficult for soft cut gaskets to absorb, uneven tightening, and external force to pipes due to temperature or pressure fluctuations, without having to modify flanges, bolt materials, or anything else.

### Specification conditions

Operating temperature range	Maximum operating pressure	Pressure class	Gasket factor (*m* value)	Minimum design seating stress (*y* value)	Minimum seating stress (*Y* value)
-104 to 300°C	15.5MPaG	Class 900 or lower	2	44.8N/mm <sup>2</sup>	29.4N/mm <sup>2</sup>

GASKET

No.2600LTL

## Low tightening pressure and high airtight type spiral wound gasket for cryogenic applications



This spiral wound gasket provides excellent sealability even under low tightening pressure where specially treated flexible graphite tape is used as filler.

- This product provides excellent sealability for cryogenic fluids (such as LNG) that unavoidably cause significant decreases in seating stress.

### Specification conditions

Operating temperature range	Maximum operating pressure	Pressure class	Gasket factor (*m* value)	Minimum design seating stress (*y* value)	Minimum seating stress (*Y* value)
-270 to 300°C	15.5MPaG	Class 900 or lower	2	44.8N/mm <sup>2</sup>	29.4N/mm <sup>2</sup>

GASKET

No.2500

Spiral wound gasket



This spiral wound gasket has an impervious layer made up of a flexible graphite tape on its outer side and a highly resilient inorganic fiber tape on its inner side.

Specification conditions

Operating temperature range	Maximum operating pressure	Pressure class	Gasket factor ("m" value)	Minimum design seating stress ("y" value)	Minimum seating stress ("Y" value)
-200 to 500°C*	25.9MPaG	Class 1500 or lower	3	68.9N/mm <sup>2</sup>	39.2N/mm <sup>2</sup>

\*When the gasket is used in an oxidizing atmosphere, the operating temperature must be no greater than 450°C.

GASKET

No.2700

Spiral wound gasket for high temperature applications



This spiral wound gasket has an impervious layer made up of a flexible graphite tape in its intermediate section and a highly resilient inorganic fiber tape on its inner and outer sides.

- This product can be used in high-temperature areas exceeding 450°C where general-purpose spiral wound gaskets employing flexible graphite tape as filler cannot be used.
- Pipe design for flanges, bolts, and other parts is the same as for spiral wound gaskets employing flexible graphite tape as filler.

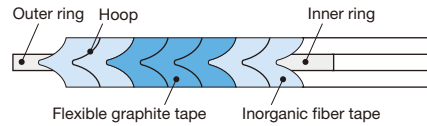

Specification conditions

Operating temperature range	Maximum operating pressure	Pressure class	Gasket factor ("m" value)	Minimum design seating stress ("y" value)	Minimum seating stress ("Y" value)	
					Water/oil-based fluid	Gas-based fluid
-200 to 650°C	43.1MPaG*	Class 2500 or lower*	3	68.9N/mm <sup>2</sup>	34.3N/mm <sup>2</sup>	78.5N/mm <sup>2</sup>

\*For gas-based fluids, the maximum operating pressure is 25.9 MPaG and the pressure class is Class 1500 or lower.

GASKET

No.5600 (No.5600N)

Technograph™ Sheet (Non-asbestos jointing sheet)



This soft cut gasket is mainly composed of flexible graphite and reinforced with aramid fiber to provide excellent flexibility and adaptivity.

- Flexible graphite, which is used as the main material of this product, provides heat resistance and high-temperature stability that cannot be provided by conventional products.
- A large sheet type with 2,540 × 3,810 mm dimensions is also available, which can be used for large-diameter devices.
- The product lineup also includes the No. 5600N gasket, which controls the chlorine ion concentration below 100 ppm.

■ Dimensions (For No. 5600 only)

Sheet size (mm)	1270 × 1270, 1270 × 3810, 2540 × 3810					
Standard thickness (mm)	0.5	0.8	1.0	1.5	2.0	3.0

■ Specification conditions

Operating temperature range	Maximum operating pressure	Thickness (t)	Gasket factor (*m* value)	Minimum design seating stress (*y* value)	Minimum seating stress (*Y* value)	
					Water/oil-based fluid	Gas-based fluid
-50 to +260℃	4MPaG	1.0 max.	3.5	44.8N/mm <sup>2</sup>	14.7N/mm <sup>2</sup>	39.2N/mm <sup>2</sup>
		1.5, 2.0	2.75	25.5N/mm <sup>2</sup>		
		3.0	2	11.0N/mm <sup>2</sup>		

GASKET

No.5650

General-purpose non-asbestos jointing sheet

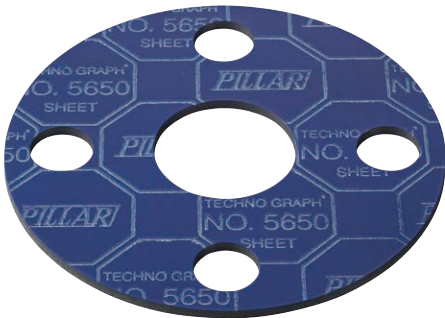

This soft cut gasket is composed mainly of graphite and reinforced with a small amount of aramid fiber.

- The surface of the gasket is subjected to special coating to prevent adhesion, making removal easier.

■ Dimensions

Sheet size (mm)	1500 × 3000	1500 × 1500	1500 × 2000			
Standard thickness (mm)	0.5	0.8	1.0	1.5	2.0	3.0

Note: The product lineup also includes the following sheet sizes: 1,500 × 1,500 mm for standard thickness 0.5 mm and 1,000 × 1,500 mm for standard thicknesses 1.5 to 3.0 mm.

■ Specification conditions

Operating temperature range	Maximum operating pressure	Pressure class	Thickness (t)	Gasket factor (*m* value)	Minimum design seating stress (*y* value)	Minimum seating stress (*Y* value)	
						Water/oil-based fluid	Gas-based fluid
-100 to +260℃	5.2MPaG	Class 300 or lower	1.0 max.	3.5	44.8N/mm <sup>2</sup>	14.7N/mm <sup>2</sup>	39.2N/mm <sup>2</sup>
			1.5, 2.0	2.75	25.5N/mm <sup>2</sup>		
			3.0	2	11.0N/mm <sup>2</sup>		

GASKET

No.5611

General-purpose non-asbestos jointing sheet

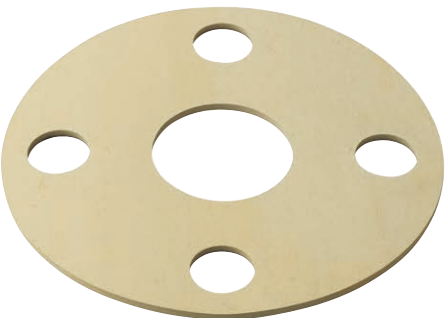

This product is a general-purpose jointing sheet composed of inorganic fiber and aramid fiber mixed with a rubber binder.

- This product features high elasticity, little creep, and smooth surfaces, as well as good affinity with flange surfaces and excellent sealability.

■ Dimensions

Sheet size (mm)	1270 × 1270, 1270 × 3810, 2540 × 3810					
Standard thickness (mm)	0.5	0.8	1.0	1.5	2.0	3.0

■ Specification conditions

Operating temperature range	Maximum operating pressure	Pressure class	Thickness (t)	Gasket factor (*m* value)	Minimum design seating stress (*y* value)	Minimum seating stress (*Y* value)
						Water/oil-based fluid
-50 to +120℃	3.3MPaG	JIS20K or lower	1.0 max.	3.5	44.8N/mm <sup>2</sup>	14.7N/mm <sup>2</sup>
			1.5, 2.0	2.75	25.5N/mm <sup>2</sup>	
			3.0	2	11.0N/mm <sup>2</sup>	

GASKET

No.6630 (No.6630N)

PILLARFOIL™ soft cut gasket



This product is a flexible graphite soft cut gasket.

- This gasket takes advantage of excellent heat resistance, chemical resistance, sealability, elasticity, and other features of flexible graphite.
- The product lineup also includes the No. 6630N gasket, which controls the chlorine ion concentration below 100 ppm.

■ Dimensions (For No. 6630 only)

Sheet size (mm)	600 × 600, 1000 × 1000						
Standard thickness (mm)	0.38	0.5	0.8	1.0	1.5	2.0	3.0

Note: For the standard thicknesses of No. 6630N, please contact us.

■ Specification conditions

Operating temperature range	Maximum operating pressure	Pressure class	Gasket factor ("m" value)	Minimum seating stress ("Y" value)
-270 to +400°C*	2.6MPaG	JIS16K or lower	2	24.5N/mm <sup>2</sup>

\* Operating temperature range of No. 6630N: -200 to +400°C

GASKET

No.6631

PILLARFOIL™ soft cut gasket with a metal plate



This product is a flexible graphite soft cut gasket reinforced with a thin stainless steel plate.

- Thicknesses and stainless steel specifications (thickness and material) are optional. Please consult with us separately for more information.

■ Specification conditions

Operating temperature range	Maximum operating pressure	Pressure class	Gasket factor ("m" value)	Minimum seating stress ("Y" value)
-270 to +400°C	5.2MPaG	Class 300 or lower	2	24.5N/mm <sup>2</sup>

GASKET

No.6633 (No.6633N)

Metal foil inserted PILLARFOIL™ soft cut gasket



This product is a soft cut gasket laminated with SUS316L stainless steel foils in the flexible graphite sheet.

- The flexible graphite sheet provides excellent heat resistance, flexibility, adaptivity to flange surfaces, elasticity, impermeability, and other features required for seal materials.
- The metal foils enhance breakage resistance and tear resistance to provide excellent handleability.
- The product lineup also includes the No. 6633N gasket, which controls the chlorine ion concentration below 100 ppm.

■ Dimensions (For No. 6633 only)

Sheet size (mm)	1000 × 1000					
Standard thickness (mm)	0.5	0.8	1.0	1.5	2.0	3.0

Note: For the standard thicknesses of No. 6633N, please contact us.

■ Specification conditions

Operating temperature range	Maximum operating pressure	Pressure class	Gasket factor ("m" value)	Minimum seating stress ("Y" value)(*2)
-270 to +400°C*1	5.2MPaG	Class 300 or lower	2*2	24.5N/mm <sup>2</sup>

\*1: Operating temperature range of No. 6633N: -200 to +400°C  
\*2: For details on No. 6633N, please contact us separately.

GASKET

No.5001

## Rubber sheet gasket



This product is a general-purpose soft cut gasket composed of rubber only.

- This gasket enables sealing with low seating stress.
- NBR, CR, CSM, EPDM, FKM, NR, SBR, and SI can be used as rubber materials.

### Product number representation

PILLAR No. **5001-NBR**

Product number      Rubber material abbreviation

### Specification conditions

Operating temperature range	Maximum operating pressure	Gasket factor ("m" value)	Minimum design seating stress ("y" value)
0 to +100°C*	1.0MPaG	0.5	1.4N/mm <sup>2</sup>

\*This temperature range applies to NBR.

GASKET

No.5002

## Rubber sheet gasket with fiber cloth



This product is a rubber sheet gasket reinforced with special fiber cloth. It provides higher strength than general-purpose rubber sheet gaskets.

- NBR and CR are used as the standard rubber materials.

### Product number representation

PILLAR No. **5002-NBR**

Product number      Rubber material abbreviation

### Specification conditions

Operating temperature range	Maximum operating pressure	Gasket factor ("m" value)	Minimum design seating stress ("y" value)
0 to +100°C	1.0MPaG	1.25	2.8N/mm <sup>2</sup>

GASKET

No.5003-NBR

## High-strength rubber sheet gasket with aramid fiber



This product is a rubber sheet gasket composed of NBR reinforced with aramid short-fiber composites.

- Compared with general-purpose rubber sheets, this product features excellent pressure resistance, little seal extrusion, and small stress relaxation.
- This product conforms to Type 1 No.1 of JIS K 6353 "Rubber goods for water works."

### Specification conditions

Operating temperature range	Maximum operating pressure	Gasket factor ("m" value)	Minimum seating stress ("Y" value)
-30 to +120°C	2.6MPaG	1.5*	3.9N/mm <sup>2</sup> *

\*When using this product with lined flanges, please contact us separately.

GASKET

No.2502LT-EOS

Low-tightening pressure general-purpose thin type gasket



This spiral wound gasket is manufactured by arranging specially treated flexible graphite fillers on the outer side and inorganic fiber fillers on the inner side, winding them with a stainless steel hoop.

- With this product, there is no need to modify flanges, bolt materials, or anything else in locations where soft cut gaskets were formerly used. This product can provide sufficient sealability with seating stress equivalent to that of soft cut gaskets.
- This product can be used in high-temperature areas where it is difficult to use soft cut gaskets. It can also be retightened after it is subjected to a heat load.

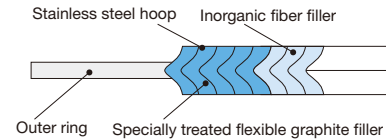

■ Specification conditions

Operating temperature range	Maximum operating pressure	Pressure class	Gasket factor ("m" value)	Minimum design seating stress ("Y" value)	Minimum seating stress ("Y" value)
-50 to +450°C	1.4MPaG	JIS 10K	2	25.5N/mm <sup>2</sup>	29.4N/mm <sup>2</sup>

GASKET

No.1200G-H

Corrugated metal gasket coated with flexible graphite



This product is a corrugated metal gasket coated with flexible graphite manufactured by laminating both sides of a concentrically corrugated stainless steel plate with flexible graphite sheets.

- This product provides high sealability at low tightening torque, high-level followability in response to equipment precision due to a large amount of compression, and other excellent features.

■ Specification conditions

Operating temperature range	Maximum operating pressure	Pressure class	Gasket factor ("m" value)	Minimum seating stress ("Y" value)
-270 to +450°C*	5.2MPaG	Class 300 or lower	2	39.2N/mm <sup>2</sup>

\*When the gasket is used in an oxidizing atmosphere, the operating temperature must be no greater than 400°C.

GASKET

No.9900-T

Inorganic sheet gasket for high temperature gas

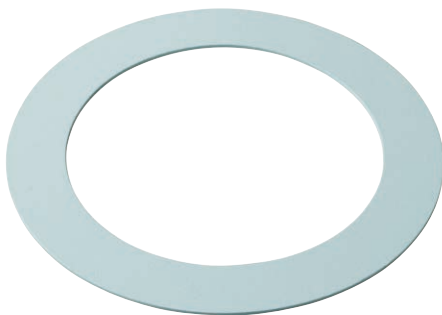

This soft cut gasket employs inorganic fiber as its main material and consists of an inorganic filler and binder.

■ Specification conditions

Operating temperature range	Maximum operating pressure
0 to 1000°C	0.2MPaG

GASKET

No.6660

## PILLARFOIL™ Plain-Tape



This tape is manufactured by cutting flexible graphite into a tape shape and applying adhesive onto one side of the tape to make it easier to use.

- When the surface of an existing gasket has become coarse or the gasket no longer provides sufficient sealability due to aging, for example, this tape can be affixed onto the mating flange or the gasket.
- This tape can be used regardless of the size and shape of the flange.
- This product can be used as a sealant tape.

### Dimensions

Width (mm) × Length (m) × Thickness (mm)
12.7 × 7.6 × 0.12
12.7 × 7.6 × 0.25
25.4 × 15.2 × 0.25
25.4 × 7.6 × 0.12

GASKET

No.6670

## PILLARFOIL™ Crinkle-Tape



This tape is manufactured by adding fine wrinkles to No. 6660.

- When the surface of an existing gasket has become coarse or the gasket no longer provides sufficient sealability due to aging, for example, this tape can be affixed onto the mating flange or the gasket.
- This tape can be used regardless of the size and shape of the flange.
- This product can be used as a sealant tape.

### Dimensions

Width (mm) × Length (m) × Thickness (mm)
12.7 × 7.6 × 0.38
25.4 × 15.2 × 0.38

GASKET

No.3300

Expanded PTFE joint sealant



This product is a uniaxially oriented ePTFE rod-shaped gasket with adhesive on one side.

- Because of its flexibility, this product fits well with the mating surface and provides excellent sealability.
- This product causes little cold flow and provides excellent sealability.
- This product is provided as a reel so that only the required length of gasket needs to be cut and used each time, making its use economical.
- The product lineup also includes gaskets without adhesive.

Dimensions

Nominal size	Item number	Cross-sectional dimensions (mm)*		Standard length (m)	Applicable flange (mm)
		Thickness	Width		
3	RJ03	1.5	3.3	30	3 to 7
5	RJ05	1.8	5.0	15	7 to 10
7	RJ07	2.4	6.7	15	10 to 17
10	RJ10	3.2	10.2	8	17 to 25
14	RJ14	4.7	14.0	5	25 to 40
17	RJ17	5.9	17.0	5	40 to 50
20	RJ20	6.5	18.5	5	50 to 65
25	RJ25	8.6	24.0	5	65 or more

\*The cross-sectional dimensions are reference dimensions.

Specification conditions

Operating temperature range	Maximum operating pressure	Gasket factor ("m" value)	Minimum seating stress ("Y" value)
			Water/oil-based fluid
-100 to 200°C	3.3MPaG	1.5	17.2N/mm <sup>2</sup>

GASKET

No.3300-F

Expanded PTFE joint sealant



This product is a uniaxially oriented ePTFE rod-shaped gasket with adhesive on one side.

- This product is a one-size-fits-all gasket best suited for clean applications.

Dimensions

Nominal size	Cross-sectional dimensions (mm)*		Standard length (m)
	Thickness	Width	
3×25M	1.5	3.0	25
7×25M	2.5	7.0	25
10×10M	3.0	10.0	10
14×10M	5.0	14.0	10
17×8M	6.0	17.0	8
20×5M	7.0	20.0	5

\*The cross-sectional dimensions are reference dimensions.

Specification conditions

Operating temperature range	Maximum operating pressure	Gasket factor ("m" value)	Minimum seating stress ("Y" value)
			Water/oil-based fluid
-100 to 200°C	3.3MPaG	1.5	17.2N/mm <sup>2</sup>

GASKET

No.3330

Expanded PTFE flat joint sealant



This product is a uniaxially oriented ePTFE tape-shaped gasket with adhesive on one side.

- The product lineup also includes gaskets without adhesive.

Dimensions

Item number	Thickness (mm)	Dimensions	
		Width (mm)	Length (m)
FJ1100	1.0	100	15
FJ1050	1.0	50	15
FJ1025	1.0	25	15
FJ1550	1.5	50	10
FJ1525	1.5	25	10
FJ3050	3.0	50	5
FJ3030	3.0	30	5
FJ3015	3.0	15	7
FJ3010	3.0	10	7

Note: The dimensions are reference dimensions.

Specification conditions

Operating temperature range	Maximum operating pressure	Gasket factor ("m" value)	Minimum seating stress ("Y" value)
			Water/oil-based fluid
-100 to 200°C	3.3MPaG	1.5	17.2N/mm <sup>2</sup>



GASKET

No.3350

## Expanded PTFE hyper sheet gasket



This product is a biaxially oriented ePTFE sheet-shaped soft cut gasket.

- This product has very soft surfaces and easily fits even rough surfaces, providing good sealability.
- This product provides excellent thermal creep resistance, compared with solid PTFE soft cut gaskets.

### Dimensions

Sheet size (mm)	1500 × 1500, 1500 × 3000						1500 × 1500	
Standard thickness (mm)	0.5	1.0	1.5	2.0	3.0	4.0	5.0	6.5

### Specification conditions

Operating temperature range	Maximum operating pressure	Gasket factor ("m" value)	Minimum seating stress ("Y" value)
			Water/oil-based fluid
-100 to 200°C	3.3MPaG	3	19.6N/mm <sup>2</sup>

GASKET

No.3355

## Expanded PTFE hyper clean sheet gasket



This product is an ePTFE gasket for pipe flanges for use with high-purity wet chemicals, gases, and ultrapure water in industrial fields that require purity, such as fine chemicals, semiconductors, and LCDs.

- This product employs a locally dense structure to reduce leakage through ePTFE seals and provide high-level gas sealability.
- This product is individually packaged using clean packaging practices to maximize the cleanliness of ePTFE.

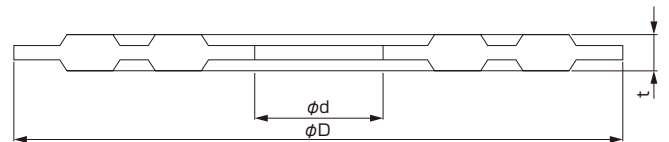

Unit: mm

Nominal size	JIS 10K raised face (RF) flanges						
	10A	15A	20A	25A	32A	40A	50A
$\phi d$	18	22	28	35	43	49	61
$\phi D$	53	58	63	74	84	89	104
t	3	3	3	3	3	3	3

GASKET

No.3356

## Expanded PTFE sanitary ferrule gasket



This product is an ePTFE gasket molded for sanitary tube clamps.

- Because of its superior heat resistance and extremely low heat deterioration, this product can handle steam cleaning and sterilization over a long period of time.
- Because of PTFE characteristics, this product minimizes cross-contamination such as color or smell absorption.

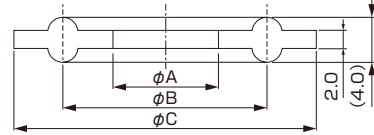

**Dimensions**

Unit: mm

	BA	10A	15A	1S	1-1/4S	1-1/2S	2S	2-1/2S	3S	3-1/2S	4S
$\phi A$	10.7	14.0	17.7	23.2	29.6	35.9	48.0	59.7	72.5	85.1	98.7
$\phi B$	27.5	27.5	27.5	43.5	43.5	43.5	56.5	70.5	83.5	97.0	110.0
$\phi C$	34.0	34.0	34.0	50.5	50.5	50.5	64.0	77.5	91.0	106.0	119.0

Note: Please consult with us separately regarding custom sizes.

GASKET

No.3356-U

## Sanitary union gasket made of fluorocarbon polymers



This product is a PFA gasket molded for threaded union fittings.

- This product provides excellent heat resistance and chemical resistance, and can be used in high-temperature steam and cleaning solutions.

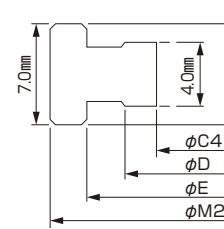

**Dimensions**

Unit: mm

Nominal size	C4	E	M2	D
1-1/2S	35.9	42.65	46.0	39.1
2S	48.0	56.1	59.5	51.9
2-1/2S	59.7	69.8	73.2	64.6

Note: The sizes shown above are based on ISO 2853:1993.

PFA Tube

No.8881

## Sanitary PFA tube

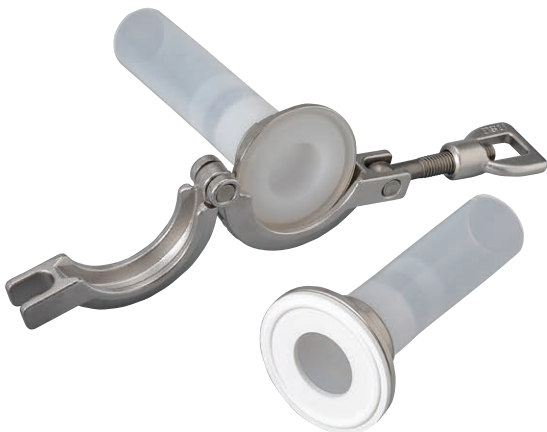

This product is a translucent, clean sanitary tube made of PFA resins.

- This tube conforms to the sanitary clamp union fitting sizes.
- This tube provides excellent heat resistance, chemical resistance, and water repellency, as well as characteristics that make it difficult for dirt to become attached to the tube and make it easy to remove dirt.
- The internal flow channel is smooth, which prevents liquid trapping and provides excellent washability.
- The tube section can be bent to provide a degree of freedom in tube design.

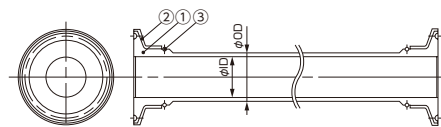

Size	$\phi OD$	$\phi ID$
8A	10	8
10A	12	10
	12.7	9.5
15A	19	15.8
1S	25	22
	25.4	22.2
1.5S	38.1	33.7

No.	Part name	Material	Qty
1	Ferrule & tube	PFA	1
2	Backup flange	SUS304 or eq. SUS316 or eq.	2
3	Spring	SUS304 or eq.	2

We can handle any combination of irregular-shaped fittings and bend tube sections. Please contact us if you are interested.

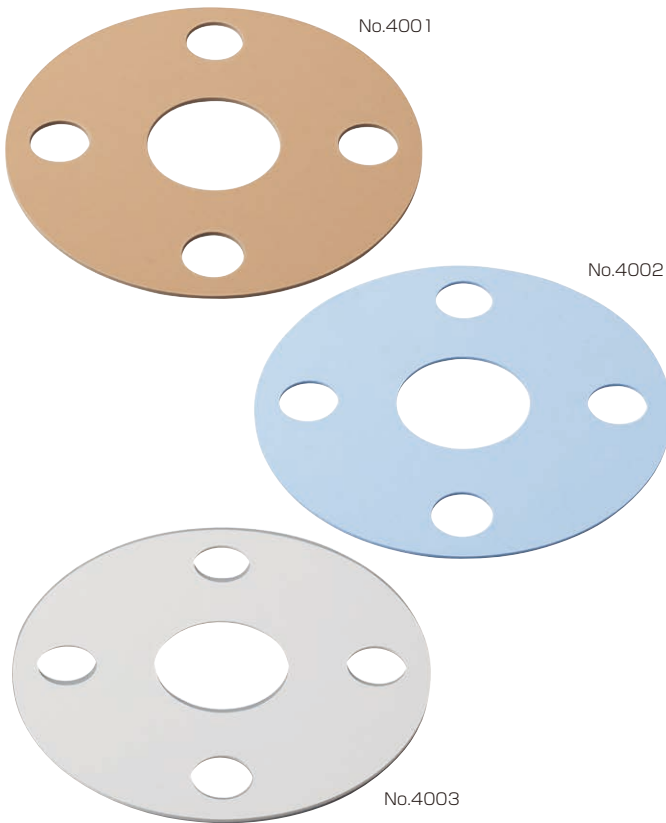

This soft cut gasket is manufactured by using PTFE as the main material and mixing a filler using our original manufacturing method.

- By preparing three types of filler to be used according to the application, we have improved creep characteristics that become problems mainly with PTFE-based gaskets.

#### ■ Dimensions

Sheet size (mm)	1500 × 1500			
Standard thickness (mm)	1.5	2.0	3.0	6.4 (For No. 4002 only)

#### ■ Performance and overview

PILLAR No.		No.4001	No.4002	No.4003
Color		Orange	Light blue	White
Filler		Silica-based filler	Special glass-based filler	Barium-based filler
Features		Low-creep Excellent acid resistance	Significant compression characteristics	Low-creep Excellent alkali resistance
Applications		For general use Strong acid (excluding hydrofluoric acid) Oxygen	For use under low tightening conditions Alternative for PTFE coated gaskets	For use in strong alkali or oxygen Waste collection services
Scope of application	Pressure P(MPaG)	8.3	5.1	8.3
	Temperature T(°C)	-210 to +260	-210 to +260	-210 to +260
	P×T (MPaG · °C)	860 max.	860 max.	860 max.
Service guide		General-purpose PTFE soft cut gasket suitable for strong acids, hydrocarbon, water, steam, oxygen, etc. (Unsuitable for strong alkalis)	For tube flanges that require low seating stress, such as lined flanges (Unsuitable for strong alkalis exceeding 80°C)	Suitable for use in chlorine, hydrocarbon, water vapor, etc., as well as for waste collection services
Applicable markets		Oil/petrochemical, mining, and general industries	Chemical, pulp, and paper making industries	Soda, pulp/paper making, oil/petrochemical, and chemical
Compliance with FDA		—	—	Complied
Gasket factor ("m" value)		2.5	2.5	2.5
Minimum design seating stress ("y" value)		19.6N/mm <sup>2</sup>	19.6N/mm <sup>2</sup>	19.6N/mm <sup>2</sup>

\* The gasket factor and minimum design seating stress indicate the values that are applicable when the gasket thickness is 3.0 mm.



This product is a jacketed gasket manufactured by lathing a PTFE material so that its inner surface is right-angled and its cross-section is U-shaped, inserting a soft filler into the U-shaped hole.

- The chemical resistance and sealability of PTFE and the elasticity of the soft filler are combined to provide excellent performance

■ Product number representation



■ Main applications

- Maintenance hatches and tank covers for oil refineries and chemical plants
- Pipe flanges with glass/resin/porcelain linings
- Pipe flanges used for corrosive chemicals (liquid or gas)
- Other pipe flanges that require electrical insulation

■ Product numbers

PILLAR No.	Name	Shape	Structure	Usage range	Standard dimensions
4410	Machined PILAFLON jacketed gasket		This product is a jacketed gasket that is manufactured by lathing a PILAFLON material so that its inner surface is right-angled and its cross-section is U-shaped, then inserting a soft filler into the U-shaped hole.	- 80 to +120°C 2.0MPaG*	φ 30 to φ 500
4411	Machined PILAFLON jacketed gasket				
4420	Pressure-bonded PILAFLON jacketed gasket		This gasket is manufactured by covering its inner surface with PILAFLON tape and performing heat sealing at a single position. It is used for irregular-shaped objects with a large diameter (φ200 mm or more).	- 80 to +120°C 2.0MPaG*	JIS 5K 10K 16K 20K 30K  ASME Class 75 Class 150 Class 300
4421	Pressure-bonded PILAFLON jacketed gasket				
4430	Lip-shaped PILAFLON jacketed gasket		This product is a jacketed gasket manufactured by making a cut on a 1-mm-thick PILAFLON disk and inserting a soft filler.		
4431	Lip-shaped PILAFLON jacketed gasket				
4432	Lip-shaped PILAFLON jacketed gasket				

\* 5.4 MPaG for FH

■ Shape symbols

Shape is classified into the following two types according to the soft filler configuration.

AF	The soft filler is made up of only a jointing sheet.
FH	The soft filler has SUS304 or equivalent stainless steel inserted into it.

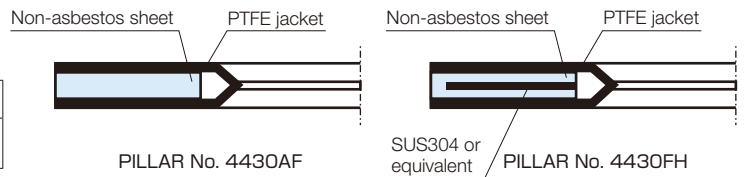



This gasket is manufactured by molding PTFE with or without a filler and then machining and cutting it.

- Gaskets without a filler provide excellent chemical resistance and cleanliness, and gaskets with a filler provide excellent mechanical strength.
- No. 4400 is a product manufactured by cutting and lathing PTFE, and No. 4401 is a product manufactured by processing PTFE with a knife.

#### ■ Product number representation

PILLAR No. **4401-G2**









Product number
Material symbol

Material symbol	Main filler	Features
W2	No filler	Excellent chemical resistance and cleanliness
G2	Glass fiber	Excellent cold flow resistance
R4	Carbon fiber	Excellent creep resistance in high-temperature and high-pressure conditions

Note: We can also manufacture gaskets using PTFE with different fillers according to the application, in addition to those shown in the table above.

In recent years, devices and equipment in various industries have become increasingly sophisticated and sealing devices have been used in harsh environments more often than ever before. PILLAR metallic gaskets, which seal off such devices and equipment, are manufactured under strict quality control and according to the characteristics of various metals to withstand high temperature, high pressure, and chemicals. Mild steel, pure iron, aluminum, copper, stainless steel, special alloy, and other alloys are used as metal materials. Generally, the desirable hardness difference between a gasket and flange is said to be around HB30.

### Types

Cross-sectional shape	Name	PILLAR No.									
		Metal materials									
		Aluminum	Copper	Pure iron	Dead soft steel	SUS304 or equivalent	SUS304L or equivalent	SUS316 or equivalent	SUS316L or equivalent	SUS321 or equivalent	F5
	Corrugated metal gasket		1200-C		1200-S	1200-E					
	Grooved gasket		1300-C		1300-S	1300-E	1300-L	1300-G	1300-H		
	Plain metal gasket	1400-A	1400-C		1400-S	1400-E	1400-L	1400-G	1400-H	1400-J	
	Octagonal ring joint gasket			1500-D	1500-S	1500-E	1500-L	1500-G	1500-H		1500-F
	Oval ring joint gasket			1501-D	1501-S	1501-E	1501-L	1501-G	1501-H		1501-F
	Pressure seal ring gasket			1502-D	1502-S	1502-E	1502-L	1502-G	1502-H	1502-J	1502-F
	Lens ring gasket			1503-D	1503-S	1503-E	1503-L	1503-G	1503-H		1503-F
	Delta ring gasket			1504-D	1504-S	1504-E	1504-L	1504-G	1504-H		1504-F
	Metal hollow O-ring					1700-E				1700-J	

**Performance** | The performance of metallic gaskets differs according to the shape or material. The following table shows the performance of gaskets with different shapes (when the material is stainless steel).

PILLAR No.	Name	Maximum allowable rating (ASME class)	Gasket factor $m$	Minimum design seating stress $y$ (N/mm <sup>2</sup> )	Flange surface roughness ( $\mu\text{mRa}$ )
1200	Corrugated metal gasket	300	3.75	52.4	0.8
1300	Grooved gasket	900	4.25	69.6	1.6
1400	Plain metal gasket	2000	6.50	179.3	0.8
1500	Octagonal ring joint gasket	4500			
1500RX	RX type ring joint gasket for high pressure	5000			
1500BX	BX type ring joint gasket for ultra-high pressure	20000			
1501	Oval ring joint gasket	4500			
1502	Pressure seal ring gasket	2500			
1503	Lens ring gasket	15000			
1504	Delta ring gasket	2000			
1700	Metal hollow O-ring	4500			

■ **Product number representation** | The product numbers of metallic gaskets are expressed as below.

## PILLAR No. 1500 - D - Ag

Product number and name	
PILLAR No.	Name
1200	Corrugated metal gasket
1200G	PILLARFOIL-adhered corrugated metal gasket
1300	Grooved gasket
1400	Plain metal gasket
1400G	PILLARFOIL-adhered plain metal gasket
1500	Octagonal ring joint gasket
1500RX	RX type ring joint gasket for high pressure
1500BX	BX type ring joint gasket for ultra-high pressure
1501	Oval ring joint gasket
1502	Pressure seal ring gasket
1503	Lens ring gasket
1504	Delta ring gasket
1509	Metallic gaskets with other shapes
1700	Metal hollow O-ring
1701	Metal hollow O-ring balanced type (Based on inner diameter)
1702	Metal hollow O-ring balanced type (Based on outer diameter)

Surface treatment symbol	
PILLAR symbol	Surface treatment material
None	None
PF	PILAFILON
Ag	Silver
N	Nickel
C	Copper
Please consult with us separately for information regarding other surface treatment materials.	

Metal material symbol		
	PILLAR symbol	Material name
Standard model	S	Dead soft steel
	D	Pure iron
	E	SUS304 or equivalent
	L	SUS304L or equivalent
	F	5Cr-0.5Mo steel (F5)
	G	SUS316 or equivalent
	H	SUS316L or equivalent
	C	Copper
	A	Aluminum
Non-standard	J	SUS321 or equivalent
	K	SUS347 or equivalent
	M	Alloy 400 or equivalent
	T	Titanium
	Other	See the table on the left.

### ■ Other metal material symbols

PILLAR symbol	Metal material name
N	Nickel
R	SUS410 or equivalent
U	SUS430 or equivalent
Z	Other

Note: If you are interested in any of the metal materials shown above, please consult with us in advance.

■ **Constituent materials** | Generally, metallic gaskets are made of the metals shown in the table below. Metal materials are indicated as PILLAR symbols at the end of a product number.

Material name		PILLAR symbol	Material hardness		Maximum operating temperature (°C)	
Category	Name		HB	HRB		
Standard model	Carbon steel	Dead soft steel	S	120 or less	70 or less	540
		Pure iron	D	90 or less	—	540
	Stainless steel	SUS304 or equivalent	E	160 or less	84 or less	800
		SUS304L or equivalent	L	150 or less	81 or less	800
		5Cr-0.5Mo steel (F5)	F	130 or less	74 or less	650
		SUS316 or equivalent	G	160 or less	84 or less	800
		SUS316L or equivalent	H	150 or less	81 or less	800
	Non-ferrous metal	Copper	C	50 or less	—	350
Aluminum		A	30 or less	—	430	
Non-standard	Stainless steel	SUS321 or equivalent	J	160 or less	84 or less	870
		SUS347 or equivalent	K	160 or less	84 or less	870
	Non-ferrous metal	Alloy 400 or equivalent	M	150 or less	81 or less	815
		Titanium	T	160 or less	84 or less	800

Note: When using any metal other than those shown above (nickel, for example), please consult with us.

GASKET

No.1200

Corrugated metal gasket

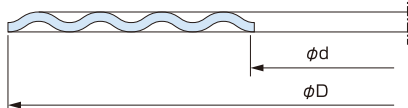

This gasket is manufactured by corrugating a thin metal sheet concentrically.

- Corrugating the thin metal sheet increases the contact pressure, which enables the spring-like effect of metal to enhance sealability.

■ Main applications

For use with valve bonnets handling high-temperature, low-pressure steam; oil; gases; solvents; heat transfer oil; etc.

\* We may be unable to manufacture this product, depending on the required specifications.

GASKET

No.1300

Grooved gasket

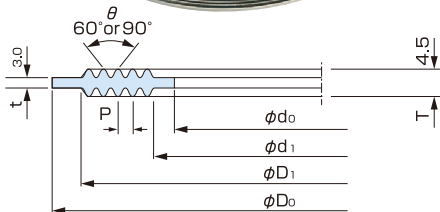

This gasket is manufactured by cutting sharp 60° or 90° V-shaped grooves concentrically on a plain metal gasket at approximately 1 mm intervals.

- Sharpening the tip of each peak increases the contact pressure, providing good sealability with low seating stress.

■ Main applications

This product is used with high-temperature, high-pressure pipe flanges with a narrow flange face or pipe flanges with low bolt strength. It is used as a gasket for devices such as mixers; heat exchangers; high-temperature, high-pressure valve bonnets; and autoclaves.

GASKET

No.1400

Plain metal gasket

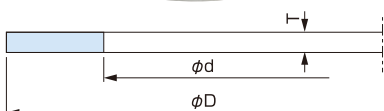

This product is a flat metallic gasket manufactured by processing plain metal to specified dimensions.

■ Main applications

This gasket is used with high-temperature, high-pressure pipe flanges for use in the steam, oil refinery, and petrochemical industries and also used on valve bonnets, boiler manholes, towers, heat exchangers, and joints and lids of devices such as autoclaves.

This product is also suitable for raised face flanges, tongue and groove flanges, and male-female flanges.



## Octagonal ring joint gasket



This gasket is manufactured by cutting and processing each metal material into an octagonal cross-section.

- This gasket has surface contact with its mating flange, widening the contact area. It can also be reused by polishing surfaces, making its use economical.
- This gasket has a linear cross-section, providing high machining accuracy.

### Main applications

This gasket is used with high-temperature, high-pressure pipe flanges (for use in the steam, oil refinery, and petrochemical industries) and also used on valve bonnets, boiler manholes, towers, heat exchangers, and joints and lids of devices such as autoclaves.

For applications related to nuclear power: High-pressure connections

For applications related to valves: High-temperature, high-pressure steam valves and process valves

For applications related to pumps: Feed pumps, boiler water circulation pumps, and high-pressure reciprocating pumps

For applications related to boilers, electric power, and ships: High-temperature and high-pressure, water supply, and main steam lines

For applications related to plants: Pipe joints in oil refineries and other plants

### Related standards

Applicable flanges: Ring type joint flanges specified by JPI-7S-15, ASME B16.5, etc.

Manufacturing standards: Materials, manufacturing methods, bearing numbers, labeling, anti-rust treatment, packaging, inspection, and other items are based on JPI-7S-23, ASME B16.20, or customer-specified standards

Standard dimensions: Based on JPI-7S-23, ASME B16.20, API SPEC 6A, or MSS SP-44

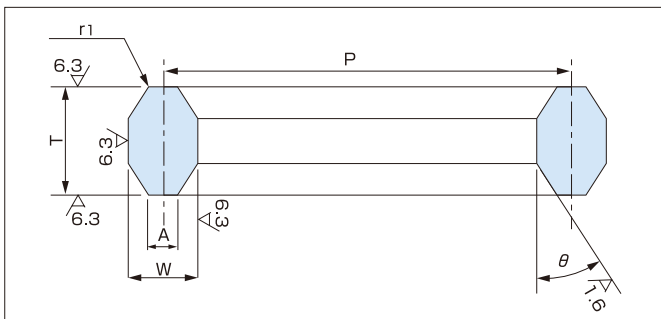

### Permissible deviations on gasket dimensions

Unit: mm

Symbol	Tolerance
P	$\pm 0.18$
W	$\pm 0.20$
T	$\pm 0.5$
A	$\pm 0.20$
$\theta$	$23^\circ \pm 0.5^\circ$
r1	$\pm 0.5$

## PILLAR No. 1500RX

RX type ring joint gasket for high pressure

## PILLAR No. 1500BX

BX type ring joint gasket for ultra-high pressure

These gaskets are used for oil-well drilling and other applications that require higher pressure resistance than octagonal ring joint gaskets. Both gaskets have been standardized in accordance with API Spec 6A (1989).

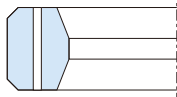
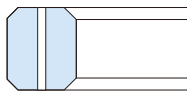
PILLAR No.	1500RX	1500BX
Applicable flange	API Spec 6A 16th Edition 1989 6B	API Spec 6A 16th Edition 1989 6BX
Standard dimensions	API Spec 6A Class 2000 to 5000	API Spec 6A Class 2000 to 20000
Shape		



This gasket is manufactured by cutting and processing each metal material into an oval cross-section.

- This gasket has surface contact with the groove section of its mating flange, making it line-contact, thereby providing excellent sealability.

### Main applications

This gasket is used with high-temperature, high-pressure pipe flanges (for use in the steam, oil refinery, and petrochemical industries) and also used on valve bonnets, boiler manholes, towers, heat exchangers, and joints and lids of devices such as autoclaves.

### Related standards

Applicable flanges: Ring type joint flanges specified by JPI-7S-15, ASME B16.5, etc.  
 Manufacturing standards: Materials, manufacturing methods, bearing numbers, labeling, anti-rust treatment, packaging, inspection, and other items are based on JPI-7S-23, ASME B16.20, or customer-specified standards

Standard dimensions: Based on JPI-7S-23, ASME B16.20, API SPEC 6A, or MSS SP-44

### Cross-sectional shape and permissible deviations on dimensions

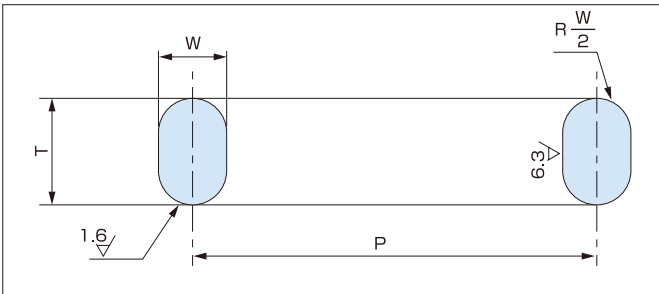

### Groove shape and permissible deviations on groove dimensions (common to octagonal and oval shapes)

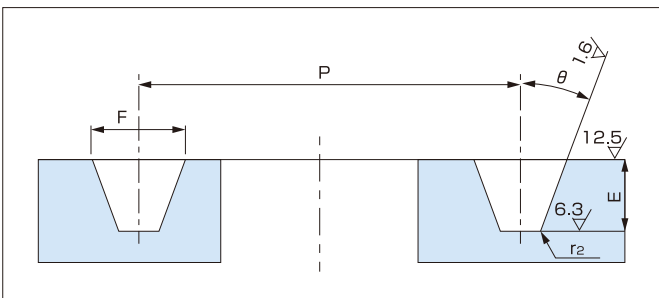

### Permissible deviations on gasket dimensions

Unit: mm

Symbol	Tolerance
P	$\pm 0.18$
W	$\pm 0.20$
T	$\pm 0.5$

### Permissible deviations on groove dimensions

Unit: mm

Symbol	Tolerance
P	$\pm 0.13$
E	+0.41
F	$\pm 0.20$
$\theta$	$23^\circ \pm 0.5^\circ$
$r_2$	1.5 or less: $\begin{matrix} +0.8 \\ 0 \end{matrix}$ , over 1.5: $\pm 0.8$

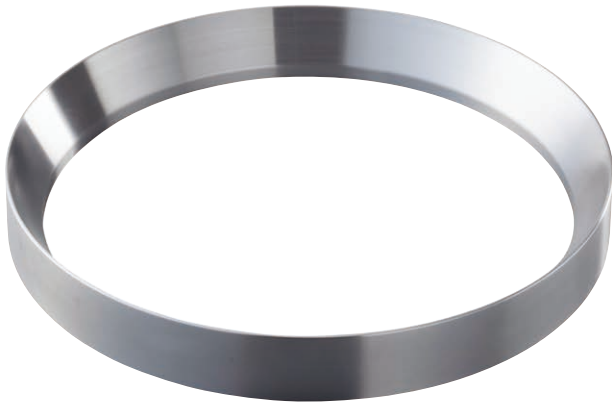

This product is a self-sealing type gasket used for high-temperature, high-pressure valve bonnets and other similar applications.

- This gasket initially applies seating stress and then utilizes the end-force of fluid pressure to expand itself in the circumferential direction and gain the end-face pressure required for sealing.

**Main applications**

This product is used for Class 900 or higher grade valves, valve bonnets, high-pressure vessel lids, and other devices for high-temperature and high-pressure heating steam.

**Features**

This product is manufactured by special processing to retain roundness and prevent distortion. Special processing also prevents work hardening and improves adaptivity with the mating materials. Surface treatment such as silver plating further improves adaptivity with the mating material.

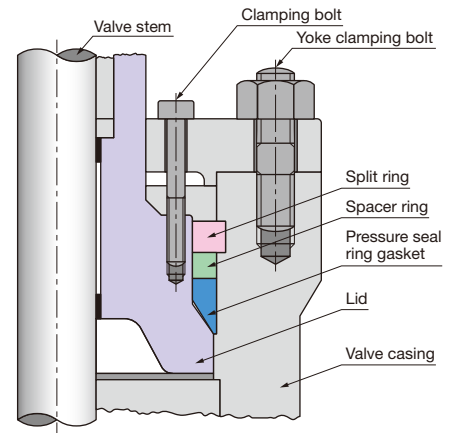

**Cross-sectional shapes and shape symbols of the pressure seal ring gasket**

Shape symbol	I	II	III	IV	V
Shape	<p>TYPE I</p>	<p>TYPE II</p>	<p>TYPE III</p>	<p>TYPE IV</p>	<p>TYPE V</p>

Shape symbol	VI	VII	VIII	IX	X
Shape	<p>TYPE VI</p>	<p>TYPE VII</p>	<p>TYPE VIII</p>	<p>TYPE IX</p>	<p>Other shapes</p>

Use one of the symbols shown above when indicating the cross-sectional shape of a pressure seal ring gasket. In principle, drawings are required to manufacture this product.

## Lens ring gasket

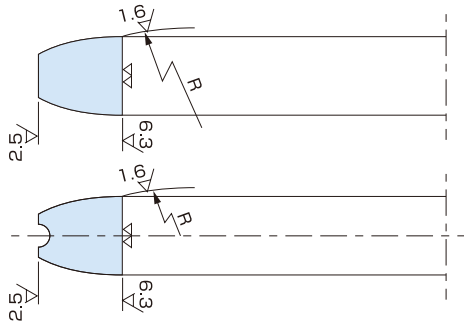

This metallic gasket is manufactured in accordance with DIN 2696.

- This gasket is used for pipe flanges in ammonia, urea, and polyethylene plants and other similar facilities.

### Main applications

This product is used for pipe flanges and pressure vessel lids in ammonia synthesis lines and methanol synthesis lines in the nitrogen industry, as well as for high-pressure polyethylene polymerization lines.

Applicable flange standards: Compliant with MSS SP-65 and DIN 2696

### Features

This gasket has line contact with the curved surface of its mating flange so that it can easily adapt to the flange surface with a smaller clamp load.

This is a high-pressure gasket that generates self-sealing capability using internal fluid pressure.

Grooved lens ring gaskets can easily be centered to the mating flange by winding a wire (or similar material) around the groove section.

## Delta ring gasket

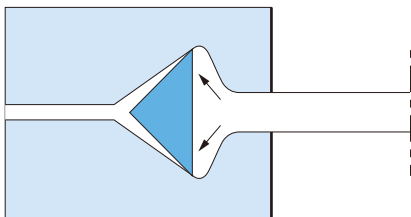

This product is a self-sealing type gasket finished with a triangular cross-section.

- This gasket is manufactured with high dimensional accuracy required as a sealing mechanism.
- Copper or silver can be plated on the surfaces.

### Main applications

This product is used for high-temperature, high-pressure autoclaves; heat exchanger lids; valve bonnets; and other similar devices.

No.1700

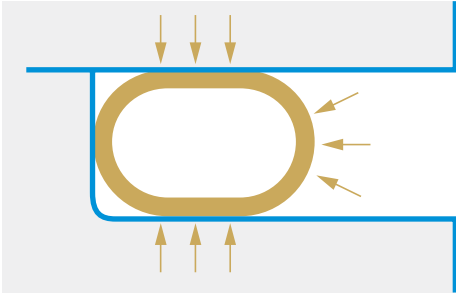

No.1701

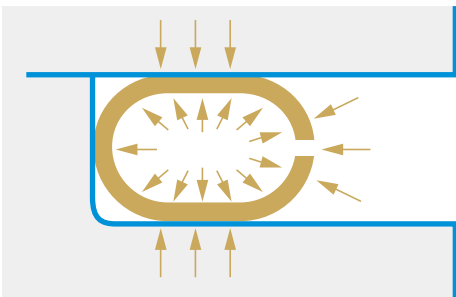

This gasket is manufactured by molding a stainless steel pipe with excellent heat resistance and corrosion resistance into a specified shape, performing butt welding at both ends of the pipe, and then grinding the surfaces and processing the surfaces with various materials as necessary.

- This gasket can also be used on complicated planar shapes with low seating stress, providing excellent performance in high-temperature, high-pressure, and high-vacuum environments.

**Main applications**

This product is used as a fixed gasket for vacuum equipment, cryostats, pressure vessels for liquefied gases, engines in high temperature conditions, and high-pressure extruders, as well as for equipment for nuclear applications, equipment related to space exploration and ocean development, and other applications.

**Features**

- **Wide operating temperature range**  
This gasket employs stainless steel pipes as the main material, enabling the gasket to be used from very low temperatures to high temperatures, up to 700°C.
- **Wide operating pressure range**  
This gasket can be used under ultra-high pressure exceeding 196 MPaG with little outgas. It can also be used under ultra-high vacuum conditions.
- **Seating stress as low as that of non-metallic gaskets**  
This gasket requires lower seating stress than other metal gaskets and only requires a small amount of space, enabling compact design.
- **Excellent chemical resistance**  
This gasket can also be manufactured as special shapes other than circular shapes.

**PILLAR No. 1701**

**Metal hollow O-ring balanced type (Based on inner diameter)**

**PILLAR No. 1702**

**Metal hollow O-ring balanced type (Based on outer diameter)**

This gasket has small holes opened in several positions inside or outside the ring. As shown in the figure on the left, the pressure inside the ring and the fluid pressure is balanced during high pressure, and the gasket generates self-sealing capability as the pressure rises. This gasket is more suitable for high pressure conditions than the basic type and is normally used when the pressure is 6.9 MPaG or higher.

**Constituent materials (Heat resistance of pipe material and surface treatment material)**

	Material	Maximum recommended temperature
Pipe material	SUS304 or equivalent	430°C
	SUS321 or equivalent	430°C
Surface treatment material	PTFE	260°C
	Silver	Same temperature as pipe material

**Pipe material dimensions**

Pipe material	Pipe outside diameter		Pipe thickness	
	Nominal	Pipe diameter (mm)	Nominal	Pipe thickness (mm)
Aa	A	1.6	a	0.25
Ab	A	1.6	b	0.5
Ba	B	2.4	a	0.25
Bb	B	2.4	b	0.5
Cb	C	3.2	b	0.5

**Surface treatment and flange surface roughness (umRa)**

Fluid	Surface treatment		
	None	PTFE coating	Silver plating
Vacuum / Gas	—	0.8	0.4
Water / Steam	0.4	0.8	0.8
Medium-viscosity oil	0.4	1.6	0.8
High-viscosity oil	0.8	1.6	1.6

**Flange clamp load**

The flange clamp load is calculated using the following formula.

$$T = R\pi D + 1/4 \pi D^2 P$$

T: Total flange load (N)  
 R: Unit clamp load of metal hollow O-ring (N/mm)  
 D: Outside diameter of metal hollow O-ring (mm)  
 P: Fluid pressure (MPaG)

**Pipe material and unit clamp load**

Nominal size of pipe material	Pipe outside diameter (mm) × Pipe thickness (mm)	Unit clamp load N/mm
Aa	1.6 × 0.25	127
Ab	1.6 × 0.5	412
Ba	2.4 × 0.25	59
Bb	2.4 × 0.5	314
Cb	3.2 × 0.5	176

**Flange groove dimensions**

Pipe diameter	Nominal outside diameter	φ D		Depth (C)	Minimum groove width (G)	Maximum radius of curvature (R)
		For internal pressure	For external pressure			
1.6	13 to 60	Do $^{+0.28}_{-0.13}$	(Do-3.2) $^{+0}_{-0.13}$	1.15 ± 0.05	1.9	0.3
	65 to 125	Do $^{+0.4}_{+0.2}$	(Do-3.2) $^{+0}_{-0.2}$			
2.4	50 to 60	Do $^{+0.28}_{-0.13}$	(Do-4.8) $^{+0}_{-0.13}$	1.95 ± 0.05	2.8	0.5
	65 to 200	Do $^{+0.4}_{+0.2}$	(Do-4.8) $^{+0}_{-0.2}$			
3.2	130 to 250	Do $^{+0.4}_{+0.2}$	(Do-6.4) $^{+0}_{-0.2}$	2.70 ± 0.05	3.7	0.8
	260 to 1000	Do $^{+0.8}_{+0.3}$	(Do-6.4) $^{+0}_{-0.33}$			

Unit: mm

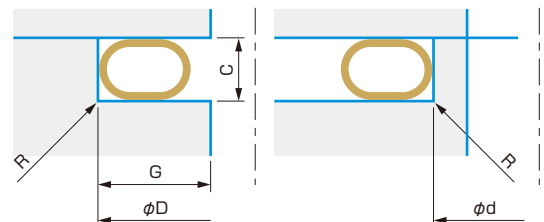

Notes 1) "Do" is the nominal outside diameter of a metal hollow O-ring.  
 2) Design a flange groove on the basis of φD and φd for internal pressure and external pressure, respectively.  
 3) For plated or coated flanges, add 0.05 mm to φD and C, and subtract 0.05 mm from φd.

Metal jacketed gasket

The metal jacketed gasket is a semi-metallic gasket that is covered with a thin metal sheet outside a soft filler such as heat-resistant thread or mill-board material. We can also manufacture gaskets with a complicated planar shape or large-diameter gaskets. Thanks to metal-like heat resistance and good cushioning characteristics provided by soft fillers, this product is used in a very wide range of fields. We also provide gaskets subjected to PILLARFOIL™ surface treatment to produce excellent sealability.

Shapes and product numbers

PILLAR No.	1050	1054	1056	1150	1650	1654
Name	Flat, double jacketed	Flat, double shell	Corrugated	Round	PILLARFOIL adhered Flat, double jacketed	PILLARFOIL adhered Flat, double shell
Shape						
Standard soft filler	Mill-board	Mill-board	Mill-board	Mill-board	Mill-board	Mill-board
Surface treatment	None	None	None	None	PILLARFOIL	PILLARFOIL

Note: For use of special soft fillers other than the combinations shown above, please consult with us separately.

Planar shapes and shape symbols

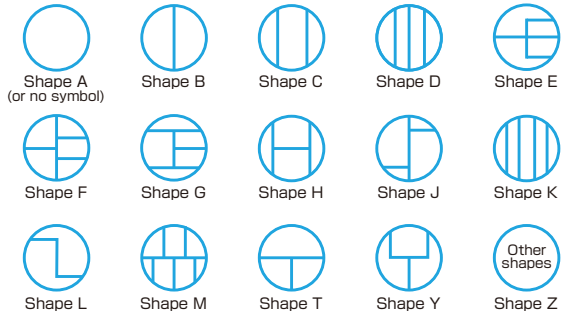

Product number representation | The product numbers of metal jacketed gaskets are expressed as below.

PILLAR No. 1050 C - S

Note: When indicating a shape, use one of the shape symbols shown in the preceding section. Drawings are required to manufacture gaskets with branches or special shapes.

Surface treatment and cross-sectional shape	
PILLAR symbol	Treatment method
0	None
1	Circular cross-section
6	PILLARFOIL adhered

Soft filler material	
PILLAR symbol	Material
5	Mill-board, non-asbestos sheet, heat-resistant thread, etc.

Covered metal material symbol		
PILLAR symbol		Material name
Standard model	E	SUS304 or equivalent
	G	SUS316 or equivalent
	C	Copper
	S	Dead soft steel
Non-standard	L	SUS304L or equivalent
	H	SUS316L or equivalent
	A	Aluminum

Shape symbol	
See the figure above.	

Product number and name	
PILLAR No.	Name
1050	Flat, double jacketed
1054	Flat, double shell
1056	Corrugated
1150	Round

Metal jacketed gasket

**Performance** | The characteristics of metal jacketed gaskets differ according to the covered metal material. The following table shows the characteristics of gaskets with different materials.

Material name		PILLAR symbol	Flange surface roughness (μmRa)	Maximum operating temperature (°C)	Maximum operating pressure (MPaG)	Gasket factor (m)	Minimum design seating stress (y)N/mm <sup>2</sup>
Standard model	Stainless steel	SUS304 or equivalent	E	1.6	530	4.9	3.75
		SUS316 or equivalent	G				
	Non-ferrous metal	Copper	C		400		3.50
	Carbon steel	Dead soft steel	S		530		3.75
Non-standard	Stainless steel	SUS304L or equivalent	L	530	3.75	62.1	
		SUS316L or equivalent	H	400	3.25		
	Non-ferrous metal	Aluminum	A	530* <sup>1</sup>	3.00	39.2* <sup>2</sup>	
PILLARFOIL adhered			6.3	530* <sup>1</sup>			

\*1: When the gasket is used in an oxidizing atmosphere, the maximum operating temperature is 400°C.  
\*2: This indicates the value per unit projected area in the seal part.

**Permissible deviations on dimensions**

PILLAR No.	Cross-sectional dimensions
1050	
1054	
1056	
1150	
1650	
1654	

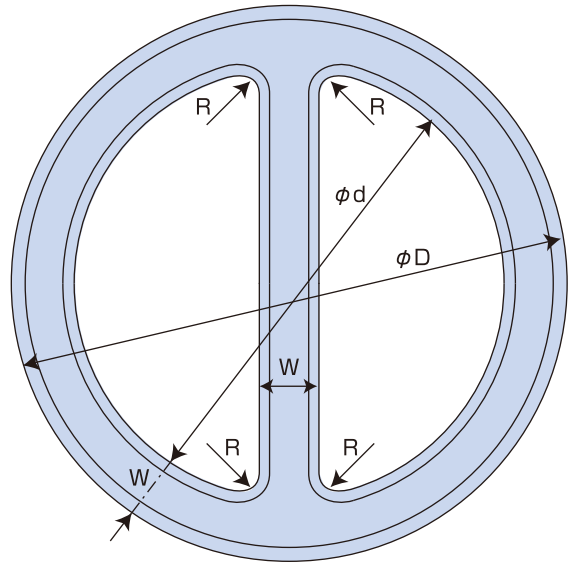

Note: Thickness "t" of No. 1650 and No. 1654 in the table on the left indicates the thickness before PILLARFOIL treatment.

Scope of manufacturing (mm)	
Manufacturable thickness	2 to 5 mm (Standard: 3 mm)*
Minimum branch width	8
Maximum outside diameter	4000

\* For thicknesses exceeding 5 mm, please consult with us separately.

**Permissible deviations on dimensions in each portion**

Portion	Dimension symbol	Range	Permissible deviations on dimensions
Turnback width	a	Linear section and outer section	3 <sup>+3</sup> <sub>0</sub>
		Branch bottom part	2.0 <sup>+3</sup> <sub>0</sub>
PILLARFOIL edge portion	e	—	0 to 1
Curved portion of branch	R	Stainless steel	12 <sup>+3</sup> <sub>0</sub>
		Carbon steel / Non-ferrous metal	10 <sup>+3</sup> <sub>0</sub>
Thickness	t	2 (inclusive) to 3 (inclusive)	±0.3
		3 (not inclusive) to 5 (inclusive)	±0.6
Branch width	W	7 (inclusive) to 16 (inclusive)	±0.5
		10 (inclusive) to 250 (inclusive)	±0.8
		250 (not inclusive) to 500 (inclusive)	±1.3
		500 (not inclusive) to 630 (inclusive)	±1.5
Inside diameter and outside diameter	d and D	630 (not inclusive) to 1000 (inclusive)	±1.8

GASKET

No.1050

### Metal jacketed gasket (Flat, double jacketed)

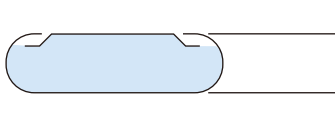

This product is a flat gasket manufactured by covering a soft filler made up of mill-board material with a single thin metal sheet.

#### ■ Main applications

This product is used in a wide range of applications, from pipe flanges on production lines handling high-temperature, high-pressure steam; gas; oil gas; solvents; and other fluids, to pressure vessel lids and cylinder head covers for internal combustion engines and air compressors. In particular, this product is used under high-temperature and high-pressure conditions unsuitable for non-metallic gaskets.

GASKET

No.1054

### Metal jacketed gasket (Flat, double shell)

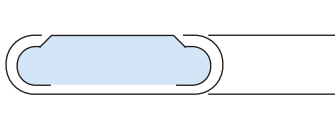

This product is a flat gasket manufactured by covering a soft filler made up of mill-board material with a thin metal sheet and tucking in a No. 1050 top plate up to the bottom surface.

#### ■ Main applications

This product is used with tongue and groove flanges and male-female flanges for pipes for use in the oil refinery and petrochemical industries. It is also used for heat exchangers, large-diameter pressure vessels, tanks, and towers.

GASKET

No.1056

### Metal jacketed gasket (Corrugated, double jacketed)

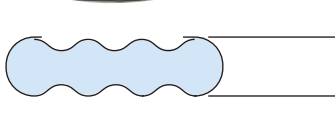

This product is a gasket manufactured by covering a soft filler made up of mill-board material with a thin metal sheet. It has a concentrically corrugated cross-sectional structure to produce high local contact pressure.

#### ■ Main applications

This product is used with raised face flanges, tongue and groove flanges, and male-female flanges on production lines handling steam, hot oil, oil gas, solvents, and other fluids for use in the oil refinery and petrochemical industries. It is also used for valve bonnets, pressure vessels, tanks, and towers.



GASKET

No.1150

## Metal jacketed gasket (Round)

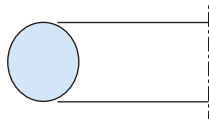

This gasket is manufactured by covering a soft filler made up of mill-board material with a thin metal sheet so that it forms a circular cross-section.

- Various planar shapes such as circular and square shapes are available.

### Main applications

This product is used in locations with limited space, such as with water pipes or boiler manholes, boiler headers, steam traps, and connection sections in internal combustion engines and heavy oil cans.

GASKET

No.1650

## Metal jacketed gasket with PILLARFOIL™ adhered (Flat, double jacketed)

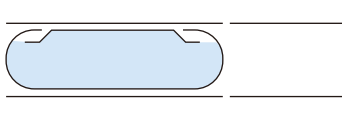
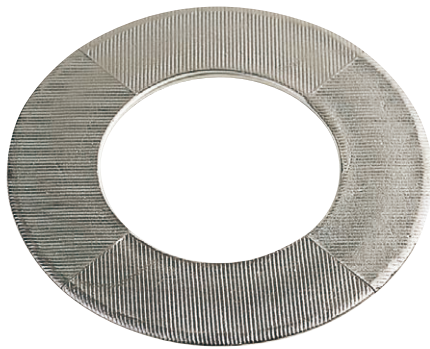

This product is a flat gasket manufactured by covering a soft filler made up of mill-board material with a single thin metal sheet and treating the gasket surfaces with flexible graphite.

- Because of its adaptivity to flange surfaces and excellent airtightness, this gasket has significantly improved sealability, which is usually a disadvantage of metal jacketed gaskets.
- This gasket provides excellent sealability with low seating stress, compared with gaskets without PILLARFOIL treatment.

### Main applications

This product is used for piping systems, heat exchangers, and valve bonnets for use in the oil refinery and petrochemical industries. It can be used for most fluids including oil, oil gas, solvents, heat transfer media, water, steam, and corrosive fluids.

### Features

This product is manufactured by treating a metal-covered gasket with flexible graphite to improve sealability. Flexible graphite with excellent heat resistance provides long-term stable performance with little influence from heating.

GASKET

No.1654

## Metal jacketed gasket with PILLARFOIL™ adhered (Flat, double shell)

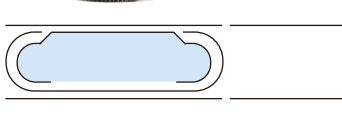
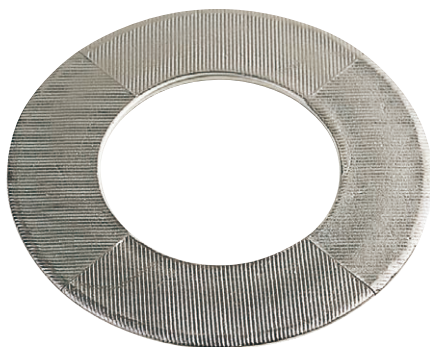

This gasket is manufactured by treating No. 1054 surfaces with flexible graphite.

- This gasket provides the best sealing performance among all metal jacketed gaskets.



No.6690-M



No.6690-C

This product is a pressure seal gasket manufactured by molding flexible graphite.

- This gasket does not generate any local force on the seal parts and does not cause abnormal deformation on the seal part of the lid.
- This gasket allows easy removal during disassembly work, which prevents scratches on the sealing surfaces, eliminating the necessity of performing corrective processing on the lid.
- This gasket is made up of highly elastic material, providing stable sealability even in temperature and pressure cycles.

**Main applications**

This product is used for valve bonnets, high-pressure vessel lids, and other devices for water and heating steam applications.

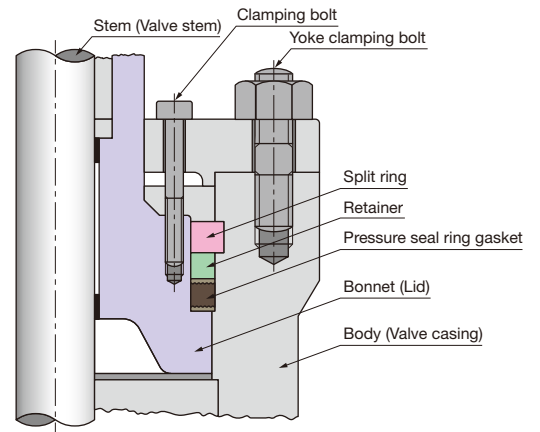

**Solving all existing problems with metal pressure seal ring gaskets at once**

**Comparison based on pressure seal gasket materials**

Item	Made of metal	Made of flexible graphite	Comparison
Characteristics with respect to temperature and pressure cycles	Leakage occurs	No leakage occurs	Because metal gaskets are hard, their followability in response to thermal expansion and contraction on the device side is poor, which may cause leakage. Because flexible graphite gaskets are soft, their followability in response to thermal expansion and contraction on the device side is good, providing stable sealability.
Initial seating stress	High	Low	Metal gaskets are hard, and therefore require high seating stress to adapt to the mating device. Flexible graphite gaskets are soft and are able to adapt to the mating device with low seating stress.
Maintainability for reuse	Corrective processing required	Corrective processing not required	Metal gaskets bite into the mating valve body to provide sealing and scratch the valve body, causing the valve to require corrective processing at the time of every periodic inspection. Flexible graphite gaskets do not scratch the mating valve body, so there is no need to perform corrective processing for the valve.
Maintainability for retightening, etc.	Retightening-based adjustment impossible	Retightening-based adjustment possible	Should leakage occur, because metal gaskets are hard, retightening-based adjustment is almost impossible. Flexible graphite gaskets are soft, enabling retightening-based adjustment.
Dimensional accuracy for the valve mounting section	Precise dimensional control required	Precise dimensional control not required	Due to the hardness of metal gaskets, precise dimensional control is required for the valve mounting section. As flexible graphite gaskets are soft and have excellent followability to the mating device, precise dimensional control is not required.
Recommended service period	2 to 4 years	4 years	Metal gaskets may cause leakage in a relatively short period of time due to the impact of temperature/pressure cycles for daily start and stop (DSS) and other operations or stress corrosion cracking (SCC) occurrence. On the other hand, flexible graphite gaskets exhibit stable characteristics over a long period of time.

**Types of No. 6690**

PILLAR No.		No.6690-M	No.6690-B	No.6690-C
Performance	Temperature	538°C max.	538°C max.	650°C max.
	Pressure	77.6MPa (Class 4500)	77.6MPa (Class 4500)	77.6MPa (Class 4500)
Characteristics		Standard model	Excellent seal extrusion into gap	Usable in high temperature areas
Cross-sectional view				

Notes: 1) This product is not recommended for gas-based fluids.  
 2) When the gasket is used in an oxidizing atmosphere, the maximum operating temperature must be 450°C.  
 3) We can also handle other shapes. For details, please contact us separately.



This product is a ring-shaped sealing part for dresser joints that is manufactured by impregnating yarn braided with flexible graphite reinforced with stainless steel wire outside the core material of the flexible graphite yarn into heat-resistant lubricant to provide impermeability, molded into a wedge-like cross-sectional shape.

- Excellent heat resistance, compared with products made of elastomer
- Best suited for fly ash transfer lines such as dust collector hoppers and desulfurization equipment
- Better cushioning characteristics and improved sealing performance, compared with equivalent existing products

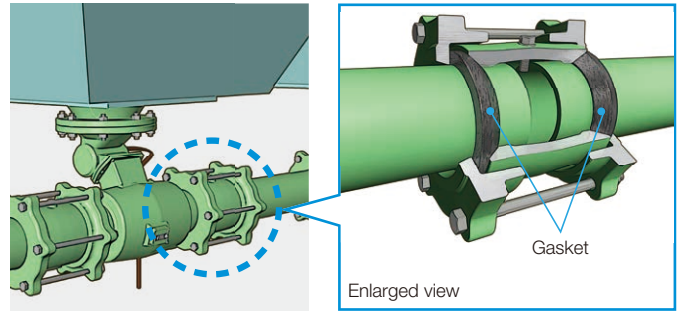

Specification conditions

Operating temperature range	Operating pressure range
-200 to +650°C	F.V. to atmospheric pressure

Sealing performance

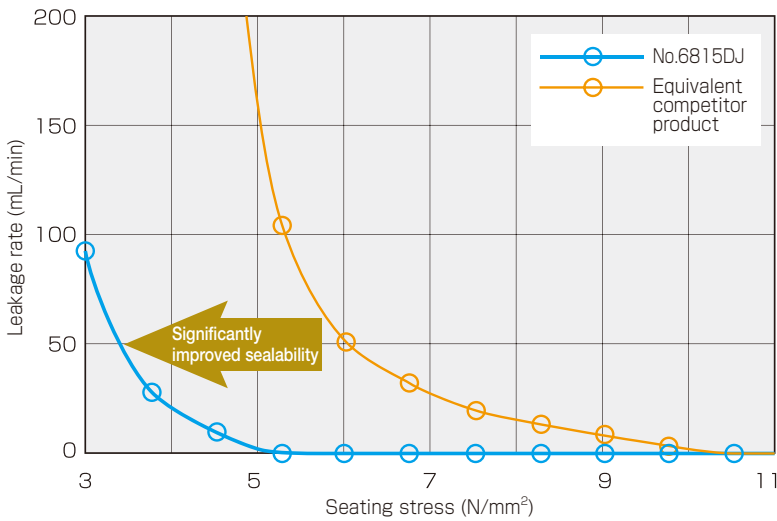

Testing conditions

Tested fluid: Air  
 Fluid pressure: -94kPaG  
 Temperature: Room temperature

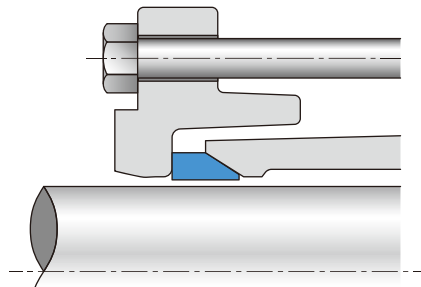

Size lineup

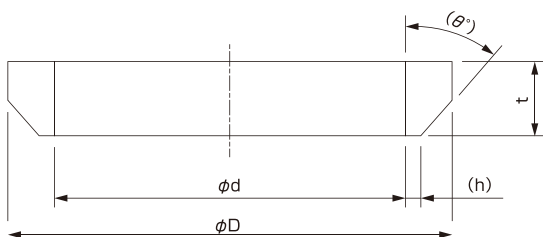

Note: We provide two types of packing: endless type, manufactured by wrapping flexible graphite tape around each joining surface, and bias-cut type.

Unit: mm

Size	φ d	φ D	t	(h)	(θ°)
100A	115	135	22	2.5	30
125A	140	169	28	3	30
150A	166	194	30	3.5	30
175A	191	224	30	3.5	30
200A	217	246	33	4	30
225A	242	278	33	4	30
250A	268	300	33	4	30
275A	299	332	33	4	30
300A	319	350	33	4.5	30

Note: The dimensions shown above are reference dimensions. Before using this product, please notify us of the dimensions of the equipment to be used. We must check whether this product can be used with the equipment.

## Gasket cutter set



This gasket cutter can be used to process original plates for joint soft cut gaskets in the field.

- Cuttable range  
Minimum inside diameter:  $\phi 24$   
Maximum outside diameter:  $\phi 600$

Spiral wound gaskets for JIS 16K to JIS 63K pipe flanges  
(basic type/with inner ring)

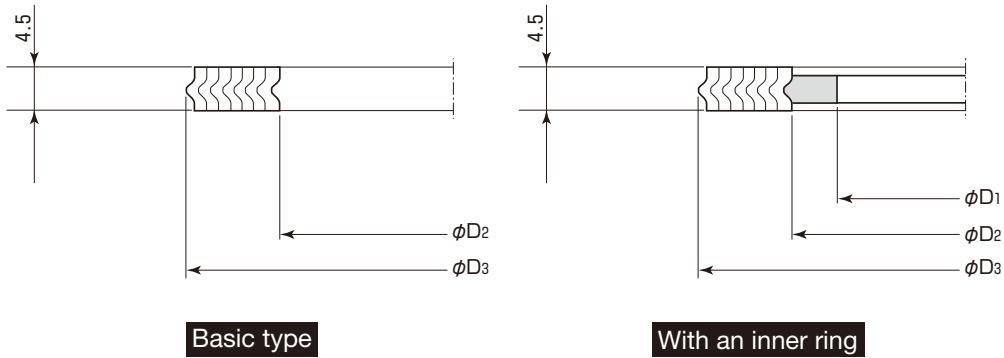

Basic type

With an inner ring

(Unit: mm)

Nominal size	For tongue and groove flanges		For male-female flanges		For male-female flanges		
	Body inside diameter D <sub>2</sub>	Body outside diameter D <sub>3</sub>	Body inside diameter D <sub>2</sub>	Body outside diameter D <sub>3</sub>	Inner ring inside diameter D <sub>1</sub>	Body inside diameter D <sub>2</sub>	Body outside diameter D <sub>3</sub>
10A	28	38	25	38	19	25	38
15	32	42	29	42	23	29	42
20	38	50	37	50	31	37	50
25	45	60	44	60	38	44	60
32	55	70	54	70	46	54	70
40	60	75	59	75	51	59	75
50	70	90	70	90	62	70	90
65	90	110	90	110	80	90	110
80	100	120	100	120	90	100	120
90	110	130	110	130	100	110	130
100	125	145	125	145	113	125	145
125	150	175	150	175	138	150	175
150	190	215	187	215	171	187	215
200	230	259	231	259	215	231	259
250	296	324	288	324	268	288	324
300	341	374	338	374	318	338	374
350	381	414	376	414	356	376	414
400	441	474	434	474	409	434	474

Note 1: These dimensions are based on JIS B 2404:1999.

Note 2: Applicable pipe flanges are JIS B 2238 and JIS B 2239 grade tongue and groove flanges and male-female flanges.  
However, the groove depth must be 5 mm or more.

Note 3: The minimum body width of PILLAR No. 2500 and No. 2501 gaskets is 6 mm.  
The minimum body width of PILLAR No. 2700 and No. 2701 gaskets is 8 mm.

For gasket body widths smaller than those shown above, please consult with us separately.

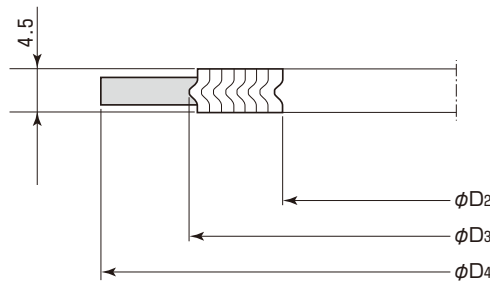

(Unit: mm)

Nominal size	10K			16K / 20K			30K		
	Body inside diameter D <sub>2</sub>	Body outside diameter D <sub>3</sub>	Outer ring outside diameter D <sub>4</sub>	Body inside diameter D <sub>2</sub>	Body outside diameter D <sub>3</sub>	Outer ring outside diameter D <sub>4</sub>	Body inside diameter D <sub>2</sub>	Body outside diameter D <sub>3</sub>	Outer ring outside diameter D <sub>4</sub>
10A	24	37	52	24	37	52	24	37	59
15	28	41	57	28	41	57	28	41	64
20	34	47	62	34	47	62	34	47	69
25	40	53	74	40	53	74	40	53	79
32	51	67	84	51	67	84	51	67	89
40	57	73	89	57	73	89	57	73	100
50	69	89	104	69	89	104	69	89	114
65	87	107	124	87	107	124	78	98	140
80	98	118	134	99	119	140	90	110	150
90	110	130	144	114	139	150	102	127	162
100	123	143	159	127	152	165	116	141	172
125	148	173	190	152	177	202	140	165	207
150	174	199	220	182	214	237	165	197	249
175	201	226	245	—	—	—	—	—	—
200	227	252	270	233	265	282	218	250	294
225	252	277	290	—	—	—	—	—	—
250	278	310	332	288	328	354	271	311	360
300	329	361	377	339	379	404	320	360	418
350	366	406	422	376	416	450	356	396	463
400	417	457	484	432	482	508	403	453	524
450	468	518	539	483	533	573	—	—	—
500	518	568	594	533	583	628	—	—	—
550	569	619	650	584	634	684	—	—	—
600	620	670	700	635	685	734	—	—	—

Nominal size	40K			63K		
	Body inside diameter D <sub>2</sub>	Body outside diameter D <sub>3</sub>	Outer ring outside diameter D <sub>4</sub>	Body inside diameter D <sub>2</sub>	Body outside diameter D <sub>3</sub>	Outer ring outside diameter D <sub>4</sub>
10A	21	34	59	21	34	64
15	24	37	64	24	37	69
20	29	42	69	29	42	75
25	35	48	79	35	48	80
32	44	60	89	44	60	90
40	51	67	100	51	67	107
50	63	79	114	63	79	125
65	78	98	140	78	98	152
80	90	110	150	90	110	162
90	102	127	162	102	127	179
100	116	141	182	116	141	194
125	140	165	224	140	165	235
150	165	197	265	165	197	275
200	218	250	315	218	250	328
250	271	311	378	271	311	394
300	320	360	434	320	360	446
350	356	396	479	356	396	488
400	403	453	531	403	453	545

For slip-on welding flanges					
Body inside diameter D <sub>2</sub>	20K			30K	
	Body outside diameter D <sub>3</sub>	Outer ring outside diameter D <sub>4</sub>	Body inside diameter D <sub>2</sub>	Body outside diameter D <sub>3</sub>	Outer ring outside diameter D <sub>4</sub>
30	42	52	36	46	59
34	46	57	41	51	64
39	51	62	45	56	69
50	63	74	54	66	79
59	73	84	62	75	89
63	78	89	69	84	100
77	93	104	83	99	114
92	112	124	100	120	140
—	—	—	—	—	—
—	—	—	—	—	—
—	—	—	—	—	—
—	—	—	—	—	—
—	—	—	—	—	—
—	—	—	—	—	—
—	—	—	—	—	—
—	—	—	—	—	—
—	—	—	—	—	—
—	—	—	—	—	—
—	—	—	—	—	—

Note 1: These dimensions are based on JIS B 2404:1999.  
 Note 2: Standardized gaskets with a nominal size of 65A or smaller for JIS 20K and 30K grade flanges cannot be applied to Type B slip-on welding flanges. The gasket dimensions shown in the "For slip-on welding flanges" column above are recommended for JIS 20K and 30K grade Type B slip-on welding flanges. Note that these dimensions were independently set by PILLAR.  
 Note 3: We can manufacture PILLAR No. 2300 series and No. 2600 series gaskets with an outer ring, but the use of these gaskets for raised face flanges is not recommended. Please use gaskets with inner and outer rings.

Note 4: The minimum body width of PILLAR No. 2502 gasket is 6 mm. The minimum body width of PILLAR No. 2702 gasket is 8 mm. For gasket body widths smaller than those shown above, please consult with us separately.

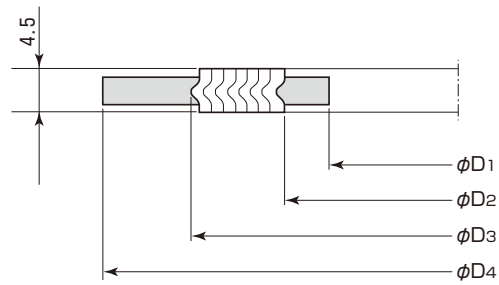

Spiral wound gasket for JIS 10K to 20K large-diameter flanges  
(with inner and outer rings)

(Unit: mm)

Nominal size	10K				16K				20K			
	Inner ring inside diameter D <sub>1</sub>	Body inside diameter D <sub>2</sub>	Body outside diameter D <sub>3</sub>	Outer ring outside diameter D <sub>4</sub>	Inner ring inside diameter D <sub>1</sub>	Body inside diameter D <sub>2</sub>	Body outside diameter D <sub>3</sub>	Outer ring outside diameter D <sub>4</sub>	Inner ring inside diameter D <sub>1</sub>	Body inside diameter D <sub>2</sub>	Body outside diameter D <sub>3</sub>	Outer ring outside diameter D <sub>4</sub>
(650)A	667	692	724	750	694	714	754	784	714	734	774	805
700	727	752	784	810	744	764	804	836	764	784	824	855
(750)	782	807	839	870	804	824	864	896	824	844	884	918
800	832	857	889	920	854	874	914	945	884	904	944	978
(850)	882	907	939	970	904	924	964	995	944	964	1004	1038
900	932	957	989	1020	954	974	1014	1045	989	1014	1054	1088
1000	1037	1062	1094	1124	1059	1084	1124	1158	—	—	—	—
1100	1147	1172	1204	1234	1159	1184	1224	1258	—	—	—	—
1200	1252	1277	1309	1344	1269	1294	1334	1368	—	—	—	—
1350	1407	1432	1464	1498	—	—	—	—	—	—	—	—
1500	1553	1578	1610	1658	—	—	—	—	—	—	—	—
Applicable flange	JIS B2220, JIS B2238, and JIS B2239				JIS B2238 and JIS B2239				JIS B2238 and JIS B2239			

Note 1: These dimensions were independently set by PILLAR.

Note 2: The minimum body width of PILLAR No. 2503 gasket is 6 mm.

The minimum body width of PILLAR No. 2703 gasket is 8 mm.

For gasket body widths smaller than those shown above, please consult with us separately.



**Spiral wound gaskets for ANSI (JPI) pipe flanges (basic type/with inner ring)**  
**For Classes 300 to 2500, flange sizes up to 600A (24B), and flanges with unified threads or metric threads**

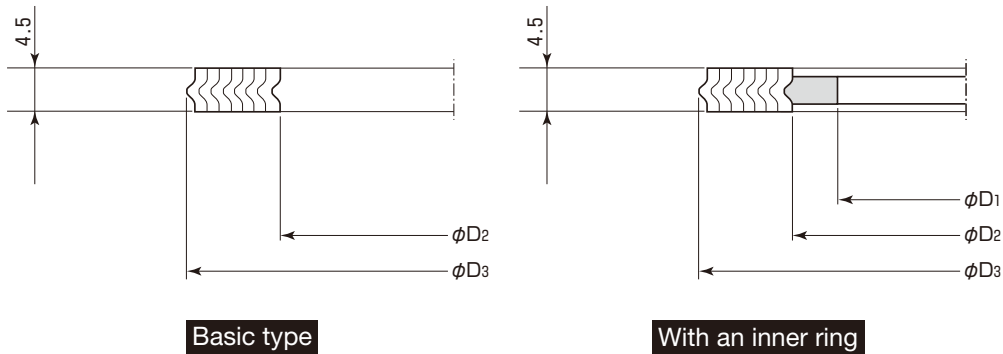

Basic type

With an inner ring

(Unit: mm)

Nominal size		Inner ring inside diameter D <sub>1</sub>					Body inside diameter D <sub>2</sub>	Body outside diameter D <sub>3</sub>
A	B	Class 300	Class 400 Class 600	Class 900	Class 1500	Class 2500		
15	1/2	14.2	14.2	14.2	14.2	14.2	25.1	35.4
20	3/4	20.6	20.6	20.6	20.6	20.6	33.0	43.2
25	1	26.9	26.9	26.9	26.9	26.9	37.8	51.1
(32)	(1 1/4)	38.1	38.1	33.3	33.3	33.3	47.2	63.8
40	1 1/2	44.4	44.4	41.4	41.4	41.4	53.5	73.5
50	2	55.6	55.6	52.3	52.3	52.3	72.6	92.5
65	2 1/2	66.5	66.5	63.5	63.5	63.5	85.3	105.2
80	3	81.0	81.0	78.7	78.7	78.7	107.6	127.3
(90)	(3 1/2)	93.7	93.7	—	—	—	120.3	140.0
100	4	106.4	102.6	102.6	97.8	97.8	131.2	157.6
(125)	(5)	131.8	128.3	128.3	124.5	124.5	160.0	186.3
150	6	157.2	154.9	154.9	147.3	147.3	190.2	216.3
200	8	215.9	205.7	196.8	196.8	196.8	237.7	270.0
250	10	268.2	255.3	246.1	246.1	246.1	285.7	323.9
300	12	317.5	307.3	292.1	292.1	291.1	342.9	381.0
350	14	349.2	342.9	320.8	320.8	—	374.6	412.8
400	16	400.0	389.9	374.6	368.3	—	425.4	469.9
450	18	449.3	438.1	425.4	425.4	—	488.9	533.4
500	20	500.1	488.9	482.6	476.2	—	533.4	584.2
600	24	603.2	590.5	590.5	577.8	—	641.8	691.7

Note 1: The permissible deviations on body thickness is  $4.5^{+0.2}_0$ .

Note 2: This gasket size table applies to large male-female flanges and large tongue and groove flanges.

Note 3: Note that the gasket inside diameter or inner ring inside diameter may exceed the flange inside diameter.

Note 4: It is desirable to use bolts all made of alloy steel (high-strength bolts made of SNB7 or higher grade).

Note 5: Avoid using the nominal sizes enclosed in parentheses wherever possible.

Note 6: The groove depths of female and groove flanges should be 5.5 mm or more, taking into account permissible deviations on gasket thickness.

Note 7: This size table is based on JPI-7S-41-2005.

Note 8: The minimum body width of PILLAR No. 2500 and No. 2501 gaskets is 6 mm.

The minimum body width of PILLAR No. 2700 and No. 2701 gaskets is 8 mm.

For gasket body widths smaller than those shown above, please consult with us separately.

GASKET

Spiral wound gasket

Spiral wound gaskets for ANSI (JPI) pipe flanges (with outer ring/with inner and outer rings)

For Classes 150 to 600, flange sizes up to 600A (24B), and flanges with unified threads

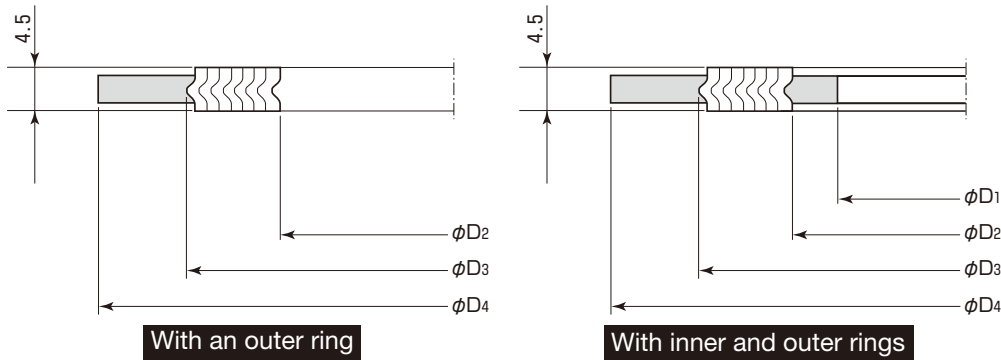

(Unit: mm)

Nominal size		Class 150				Class 300				Class 400				Class 600			
A	B	Inner ring inside diameter D <sub>1</sub>	Body inside diameter D <sub>2</sub>	Body outside diameter D <sub>3</sub>	Outer ring outside diameter D <sub>4</sub>	Inner ring inside diameter D <sub>1</sub>	Body inside diameter D <sub>2</sub>	Body outside diameter D <sub>3</sub>	Outer ring outside diameter D <sub>4</sub>	Inner ring inside diameter D <sub>1</sub>	Body inside diameter D <sub>2</sub>	Body outside diameter D <sub>3</sub>	Outer ring outside diameter D <sub>4</sub>	Inner ring inside diameter D <sub>1</sub>	Body inside diameter D <sub>2</sub>	Body outside diameter D <sub>3</sub>	Outer ring outside diameter D <sub>4</sub>
15	1/2	14.2	19.0	31.8	47.8	14.2	19.0	31.8	54.1	14.2	19.0	31.8	54.1	14.2	19.0	31.8	54.1
20	3/4	20.6	25.4	39.6	57.2	20.6	25.4	39.6	66.8	20.6	25.4	39.6	66.8	20.6	25.4	39.6	66.8
25	1	26.9	31.8	47.8	66.8	26.9	31.8	47.8	73.2	26.9	31.8	47.8	73.2	26.9	31.8	47.8	73.2
(32)	(1 1/4)	38.1	47.8	60.5	76.2	38.1	47.8	60.5	82.6	38.1	47.8	60.5	82.6	38.1	47.8	60.5	82.6
40	1 1/2	44.4	54.1	69.8	85.9	44.4	54.1	69.8	95.2	44.4	54.1	69.8	95.2	44.4	54.1	69.8	95.2
50	2	55.6	69.8	85.9	104.9	55.6	69.8	85.9	111.3	55.6	69.8	85.9	111.3	55.6	69.8	85.9	111.3
65	2 1/2	66.5	82.6	98.6	124.0	66.5	82.6	98.6	130.3	66.5	82.6	98.6	130.3	66.5	82.6	98.6	130.3
80	3	81.0	101.6	120.6	136.7	81.0	101.6	120.6	149.4	81.0	101.6	120.6	149.4	81.0	101.6	120.6	149.4
(90)	(3 1/2)	93.7	114.3	133.3	161.9	93.7	114.3	133.3	165.1	93.7	114.3	133.3	161.9	93.7	114.3	133.3	161.9
100	4	106.4	127.0	149.4	174.8	106.4	127.0	149.4	181.1	102.6	120.6	149.4	177.8	102.6	120.6	149.4	193.8
(125)	(5)	131.8	155.7	177.8	196.8	131.8	155.7	177.8	215.9	128.3	147.6	177.8	212.9	128.3	147.6	177.8	241.3
150	6	157.2	182.6	209.6	222.2	157.2	182.6	209.6	251.0	154.9	174.8	209.6	247.6	154.9	174.8	209.6	266.7
200	8	215.9	233.4	263.7	279.4	215.9	233.4	263.7	308.1	205.7	225.6	263.7	304.8	205.7	225.6	263.7	320.8
250	10	268.2	287.3	317.5	339.9	268.2	287.3	317.5	362.0	255.3	274.6	317.5	358.9	255.3	274.6	317.5	400.0
300	12	317.5	339.9	374.6	409.7	317.5	339.9	374.6	422.4	307.3	327.2	374.6	419.1	307.3	327.2	374.6	457.2
350	14	349.2	371.6	406.4	450.8	349.2	371.6	406.4	485.9	342.9	362.0	406.4	482.6	342.9	362.0	406.4	492.3
400	16	400.0	422.4	463.6	514.4	400.0	422.4	463.6	539.8	389.9	412.8	463.6	536.7	389.9	412.8	463.6	565.2
450	18	449.3	474.7	527.0	549.4	449.3	474.7	527.0	596.9	438.1	469.9	527.0	593.9	438.1	469.9	527.0	612.9
500	20	500.1	525.5	577.8	606.6	500.1	525.5	577.8	654.0	488.9	520.7	577.8	647.7	488.9	520.7	577.8	682.8
600	24	603.2	628.6	685.8	717.6	603.2	628.6	685.8	774.7	590.5	628.6	685.8	768.4	590.5	628.6	685.8	790.7

- Note 1: The permissible deviations on body thickness is  $4.5^{+0.2}_0$ .
- Note 2: It is desirable to use bolts all made of alloy steel (high-strength bolts made of SNB7 or higher grade).
- Note 3: Avoid using the nominal sizes enclosed in parentheses wherever possible.
- Note 4: We can manufacture PILLAR No. 2300 series and No. 2600 series gaskets with an outer ring, but the use of these gaskets for raised face flanges is not recommended. Please use gaskets with inner and outer rings.
- Note 5: Applicable pipe flanges are ASME B16.5-1996 and JPI-7S-15-99 grade pipe flanges.  
Note, however, that the gasket body inside diameter or inner ring inside diameter may exceed the flange inside diameter, depending on the flange shape. For flange compatibility lists, refer to Appendix 8 of JPI-7S-41-2005.

- Note 6: For metric threads, please consult with us separately.
- Note 7: The gaskets inside the bold lines above, where the nominal size is 1 inch or less, cannot be used for slip-on welding flanges. Use butt welding or socket welding. When using this product for slip-on welding flanges, use the recommended dimensions.
- Note 8: These dimensions are based on JPI-7S-41-2005.
- Note 9: The minimum body width of PILLAR No. 2502 and No. 2503 gaskets is 6 mm. The minimum body width of PILLAR No. 2702 and No. 2703 gaskets is 8 mm. For gasket body widths smaller than those shown above, please consult with us separately.

Spiral wound gasket for ANSI (JPI) slip-on welding flanges (with outer ring/with inner and outer rings) for Classes 150 to 600, flange sizes 15 to 25A (1/2 to 1B)

Nominal size		Class 150				Class 300				Class 400				Class 600			
A	B	Inner ring inside diameter D <sub>1</sub>	Body inside diameter D <sub>2</sub>	Body outside diameter D <sub>3</sub>	Outer ring outside diameter D <sub>4</sub>	Inner ring inside diameter D <sub>1</sub>	Body inside diameter D <sub>2</sub>	Body outside diameter D <sub>3</sub>	Outer ring outside diameter D <sub>4</sub>	Inner ring inside diameter D <sub>1</sub>	Body inside diameter D <sub>2</sub>	Body outside diameter D <sub>3</sub>	Outer ring outside diameter D <sub>4</sub>	Inner ring inside diameter D <sub>1</sub>	Body inside diameter D <sub>2</sub>	Body outside diameter D <sub>3</sub>	Outer ring outside diameter D <sub>4</sub>
15	1/2	18.9	24.9	34.9	48.6	18.9	24.9	34.9	54.6	18.9	24.9	34.9	54.6	18.9	24.9	34.9	54.6
20	3/4	24.7	30.7	42.3	57.6	24.7	30.7	42.3	67.8	24.7	30.7	42.3	67.8	24.7	30.7	42.3	67.8
25	1	31.3	37.3	50.3	67.2	31.3	37.3	50.3	74.4	31.3	37.3	50.3	74.4	31.3	37.3	50.3	74.4

- Note 1: These dimensions are based on JPI-7S-41-2005 and were independently set as special dimensions for slip-on welding flanges by PILLAR.
- Note 2: These dimensions apply to the unified threads specified by ANSI (JPI).

GASKET

Spiral wound gasket

Spiral wound gaskets for ANSI (JPI) pipe flanges (with outer ring/with inner and outer rings)  
For Classes 900 to 2500, flange sizes up to 600A (24B), and flanges with unified threads

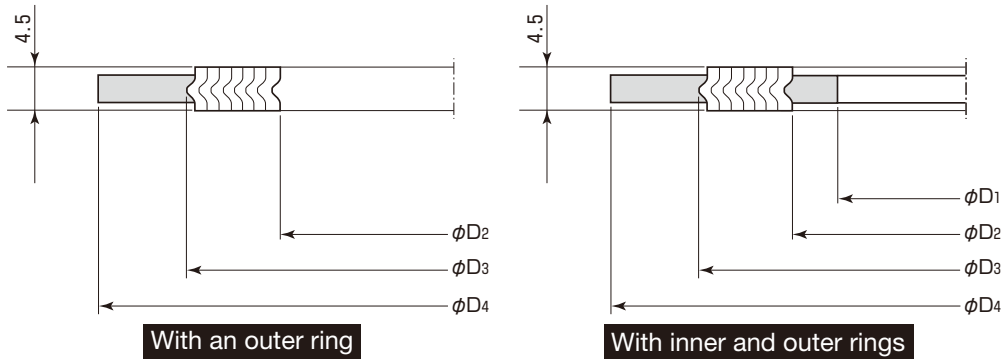

(Unit: mm)

Nominal size		Class 900				Class 1500				Class 2500			
A	B	Inner ring inside diameter D <sub>1</sub>	Body inside diameter D <sub>2</sub>	Body outside diameter D <sub>3</sub>	Outer ring outside diameter D <sub>4</sub>	Inner ring inside diameter D <sub>1</sub>	Body inside diameter D <sub>2</sub>	Body outside diameter D <sub>3</sub>	Outer ring outside diameter D <sub>4</sub>	Inner ring inside diameter D <sub>1</sub>	Body inside diameter D <sub>2</sub>	Body outside diameter D <sub>3</sub>	Outer ring outside diameter D <sub>4</sub>
15	1/2	14.2	19.0	31.8	63.5	14.2	19.0	31.8	63.5	14.2	19.0	31.8	69.8
20	3/4	20.6	25.4	39.6	69.8	20.6	25.4	39.6	69.8	20.6	25.4	39.6	76.2
25	1	26.9	31.8	47.8	79.5	26.9	31.8	47.8	79.5	26.9	31.8	47.8	85.9
(32)	(1 1/4)	33.3	39.6	60.5	88.9	33.3	39.6	60.5	88.9	33.3	39.6	60.5	104.9
40	1 1/2	41.4	47.8	69.8	98.6	41.4	47.8	69.8	98.6	41.4	47.8	69.8	117.6
50	2	52.3	58.7	85.9	143.0	52.3	58.7	85.9	143.0	52.3	58.7	85.9	146.0
65	2 1/2	63.5	69.8	98.6	165.1	63.5	69.8	98.6	165.1	63.5	69.8	98.6	168.4
80	3	78.7	95.2	120.6	168.4	78.7	92.2	120.6	174.8	78.7	92.2	120.6	196.8
(90)	(3 1/2)	—	—	—	—	—	—	—	—	—	—	—	—
100	4	102.6	120.6	149.4	206.5	97.8	117.6	149.4	209.6	97.8	117.6	149.4	235.0
(125)	(5)	128.3	147.6	177.8	247.6	124.5	143.0	177.8	254.0	124.5	143.0	177.8	279.4
150	6	154.9	174.8	209.6	289.1	147.3	171.4	209.6	282.7	147.3	171.4	209.6	317.5
200	8	196.8	222.2	257.3	358.9	196.8	215.9	257.3	352.6	196.8	215.9	257.3	387.4
250	10	246.1	276.4	311.2	435.1	246.1	266.7	311.2	435.1	246.1	270.0	311.2	476.2
300	12	292.1	323.8	368.3	498.6	292.1	323.8	368.3	520.7	292.1	317.5	368.3	549.4
350	14	320.8	355.6	400.0	520.7	320.8	362.0	400.0	577.8	—	—	—	—
400	16	374.6	412.8	457.2	574.8	368.3	406.4	457.2	641.4	—	—	—	—
450	18	425.4	463.6	520.7	638.3	425.4	463.6	520.7	704.8	—	—	—	—
500	20	482.6	520.7	571.5	698.5	476.2	514.4	571.5	755.6	—	—	—	—
600	24	590.5	628.6	679.4	838.2	577.8	616.0	679.4	901.7	—	—	—	—

Note 1: The permissible deviations on body thickness is  $4.5^{+0.2}_0$ .

Note 2: It is desirable to use bolts all made of alloy steel (high-strength bolts made of SNB7 or higher grade).

Note 3: Avoid using the nominal sizes enclosed in parentheses wherever possible.

Note 4: We can manufacture PILLAR No. 2300 series and No. 2600 series gaskets with an outer ring, but the use of these gaskets for raised face flanges is not recommended. Please use gaskets with inner and outer rings.

Note 5: Applicable pipe flanges are ASME B16.5-1996 and JPI-7S-15-99 grade pipe flanges.

Note, however, that the gasket body inside diameter or inner ring inside diameter may exceed the flange inside diameter, depending on the flange shape. For flange compatibility lists, refer to Appendix 8 of JPI-7S-41-2005.

Note 6: For metric threads, please consult with us separately.

Note 7: The gaskets inside the bold lines above, where nominal sizes of 2 1/2 inches, and 14 inches of class 900, cannot be used for slip-on welding flanges. Use butt welding or socket welding. When using this product for slip-on welding flanges, use the recommended dimensions.

Note 8: These dimensions are based on JPI-7S-41-2005.

Note 9: The minimum body width of PILLAR No. 2502 and No. 2503 gaskets is 6 mm. The minimum body width of PILLAR No. 2702 and No. 2703 gaskets is 8 mm. For gasket body widths smaller than those shown above, please consult with us separately.

Spiral wound gasket for ANSI (JPI) slip-on welding flanges (with outer ring/with inner and outer rings) for Classes 900 to 1500, flange sizes 15 to 350A (1/2 to 14B)

Nominal size		Class 900				Class 1500			
A	B	Inner ring inside diameter D <sub>1</sub>	Body inside diameter D <sub>2</sub>	Body outside diameter D <sub>3</sub>	Outer ring outside diameter D <sub>4</sub>	Inner ring inside diameter D <sub>1</sub>	Body inside diameter D <sub>2</sub>	Body outside diameter D <sub>3</sub>	Outer ring outside diameter D <sub>4</sub>
15	1/2	18.9	24.9	34.9	64.9	18.9	24.9	34.9	64.9
20	3/4	24.7	30.7	42.3	70.9	24.7	30.7	42.3	70.9
25	1	31.3	37.3	50.3	80.5	31.3	37.3	50.3	80.5
(32)	(1 1/4)	34.4	46.4	60.4	89.8	34.4	46.4	60.4	89.8
40	1 1/2	41.8	53.8	69.8	100.2	41.8	53.8	69.8	100.2
50	2	56.8	70.8	88.8	143.6	56.8	70.8	88.8	143.6
65	2 1/2	65.6	91.6	101.6	166.7	65.6	91.6	101.6	166.7
350	14	347.0	371.0	403.0	521.6	—	—	—	—

Note 1: These dimensions are based on JPI-7S-41-2005 and were independently set as special dimensions for slip-on welding flanges by PILLAR.

Note 2: These dimensions apply to the unified threads specified by ANSI (JPI).

GASKET

Spiral wound gasket

Spiral wound gaskets for ANSI (JPI) Series A pipe flanges (with outer ring/with inner and outer rings)  
For Classes 150 to 900, flange sizes 650 to 1500A (26 to 60B), and flanges with unified threads

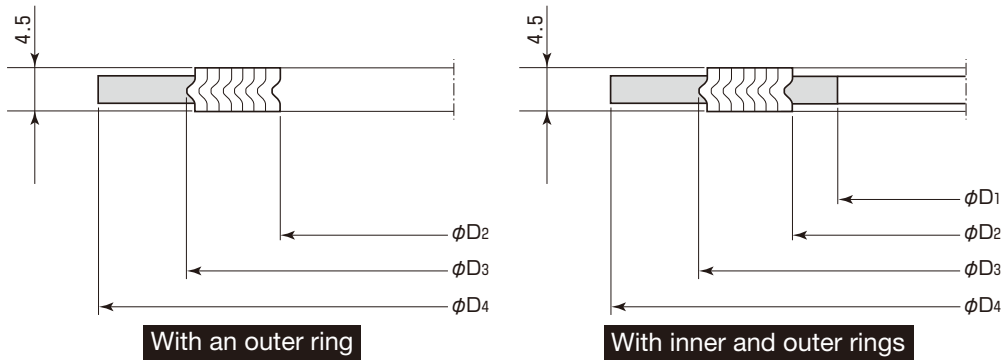

(Unit: mm)

Nominal size		Class 150				Class 300				Class 400			
		Inner ring inside diameter D <sub>1</sub>	Body inside diameter D <sub>2</sub>	Body outside diameter D <sub>3</sub>	Outer ring outside diameter D <sub>4</sub>	Inner ring inside diameter D <sub>1</sub>	Body inside diameter D <sub>2</sub>	Body outside diameter D <sub>3</sub>	Outer ring outside diameter D <sub>4</sub>	Inner ring inside diameter D <sub>1</sub>	Body inside diameter D <sub>2</sub>	Body outside diameter D <sub>3</sub>	Outer ring outside diameter D <sub>4</sub>
A	B												
650	26	654.0	673.1	704.8	774.7	654.0	685.8	736.6	835.2	660.4	685.8	736.6	831.8
700	28	704.8	723.9	755.6	831.8	704.8	736.6	787.4	898.7	711.2	736.6	787.4	892.3
750	30	755.6	774.7	806.4	882.6	755.6	793.8	844.6	952.5	755.6	793.8	844.6	946.2
800	32	806.4	825.5	860.5	939.8	806.4	850.9	901.7	1006.6	812.8	850.9	901.7	1003.3
850	34	857.2	876.3	911.4	990.6	857.2	901.7	952.5	1057.4	863.6	901.7	952.5	1054.1
900	36	908.0	927.1	968.5	1047.8	908.0	955.8	1006.6	1117.6	917.7	955.8	1006.6	1117.6
950	38	958.8	977.9	1019.3	1111.2	952.5	977.9	1016.0	1054.1	952.5	971.6	1022.4	1073.2
1000	40	1009.6	1028.7	1070.1	1162.0	1003.3	1022.4	1070.1	1114.6	1000.3	1025.7	1076.5	1127.3
1050	42	1060.4	1079.5	1124.0	1219.2	1054.1	1073.2	1120.9	1165.4	1051.1	1076.5	1127.3	1178.1
1100	44	1111.2	1130.3	1178.1	1276.4	1104.9	1130.3	1181.1	1219.2	1104.9	1130.3	1181.1	1231.9
1150	46	1162.0	1181.1	1228.9	1327.2	1152.7	1178.1	1228.9	1273.3	1168.4	1193.8	1244.6	1289.0
1200	48	1212.8	1231.9	1279.7	1384.3	1209.8	1235.2	1286.0	1324.1	1206.5	1244.6	1295.4	1346.2
(1250)	(50)	1263.6	1282.7	1333.5	1435.1	1244.6	1295.4	1346.2	1378.0	1257.3	1295.4	1346.2	1403.4
(1300)	(52)	1314.4	1333.5	1384.3	1492.2	1320.8	1346.2	1397.0	1428.8	1308.1	1346.2	1397.0	1454.2
1350	54	1358.9	1384.3	1435.1	1549.4	1352.6	1403.4	1454.2	1492.2	1352.6	1403.4	1454.2	1517.6
(1400)	(56)	1409.7	1435.1	1485.9	1606.6	1403.4	1454.2	1505.0	1543.0	1403.4	1454.2	1505.0	1568.4
(1450)	(58)	1460.5	1485.9	1536.7	1663.7	1447.8	1511.3	1562.1	1593.8	1454.2	1505.0	1555.8	1619.2
1500	60	1511.3	1536.7	1587.5	1714.5	1524.0	1562.1	1612.9	1644.6	1517.6	1568.4	1619.2	1682.8

Nominal size		Class 600				Class 900			
		Inner ring inside diameter D <sub>1</sub>	Body inside diameter D <sub>2</sub>	Body outside diameter D <sub>3</sub>	Outer ring outside diameter D <sub>4</sub>	Inner ring inside diameter D <sub>1</sub>	Body inside diameter D <sub>2</sub>	Body outside diameter D <sub>3</sub>	Outer ring outside diameter D <sub>4</sub>
A	B								
650	26	647.7	685.8	736.6	866.9	666.8	685.8	736.6	882.6
700	28	698.5	736.6	787.4	914.4	711.2	736.6	787.4	946.2
750	30	755.6	793.8	844.6	971.6	774.7	793.8	844.6	1009.6
800	32	812.8	850.9	901.7	1022.4	812.8	850.9	901.7	1073.2
850	34	863.6	901.7	952.5	1073.2	863.6	901.7	952.5	1136.6
900	36	917.7	955.8	1006.6	1130.3	920.8	958.8	1009.6	1200.2
950	38	952.5	990.6	1041.4	1104.9	1009.6	1035.0	1085.8	1200.2
1000	40	1009.6	1047.8	1098.6	1155.7	1060.4	1098.6	1149.4	1251.0
1050	42	1066.8	1104.9	1155.7	1219.2	1111.2	1149.4	1200.2	1301.8
1100	44	1111.2	1162.0	1212.8	1270.0	1155.7	1206.5	1257.3	1368.6
1150	46	1162.0	1212.8	1263.6	1327.2	1219.2	1270.0	1320.8	1435.1
1200	48	1219.2	1270.0	1320.8	1390.6	1270.0	1320.8	1371.6	1485.9
(1250)	(50)	1270.0	1320.8	1371.6	1447.8	—	—	—	—
(1300)	(52)	1320.8	1371.6	1422.4	1498.6	—	—	—	—
1350	54	1378.0	1428.8	1479.6	1555.8	—	—	—	—
(1400)	(56)	1428.8	1479.6	1530.4	1612.9	—	—	—	—
(1450)	(58)	1473.2	1536.7	1587.5	1633.7	—	—	—	—
1500	60	1530.4	1593.8	1644.6	1733.6	—	—	—	—

Note 1: The permissible deviations on body thickness is  $4.5^{+0.2}_0$ .

Note 2: It is desirable to use bolts all made of alloy steel (high-strength bolts made of SNB7 or higher grade).

Note 3: Avoid using the nominal sizes enclosed in parentheses wherever possible.

Note 4: We can manufacture PILLAR No. 2300 series and No. 2600 series gaskets with an outer ring, but the use of these gaskets for raised face flanges is not recommended. Please use gaskets with inner and outer rings.

Note 5: Applicable pipe flanges are ANSI B16.47-1996 Series A (formerly MSS SP-44) and JPI-7S-43-95 Series A grade butt welding flanges.

Note 6: For metric threads, please consult with us separately.

Note 7: These dimensions are based on JPI-7S-41-2005.

Note 8: The minimum body width of PILLAR No. 2502 and No. 2503 gaskets is 6 mm.

The minimum body width of PILLAR No. 2702 and No. 2703 gaskets is 8 mm.

For gasket body widths smaller than those shown above, please consult with us separately.

GASKET

Spiral wound gasket

Spiral wound gaskets for ANSI (JPI) Series B pipe flanges (with outer ring/  
with inner and outer rings)  
For Classes 150 to 900, flange sizes 650 to 1500A (26 to 60B), and flanges with  
unified threads

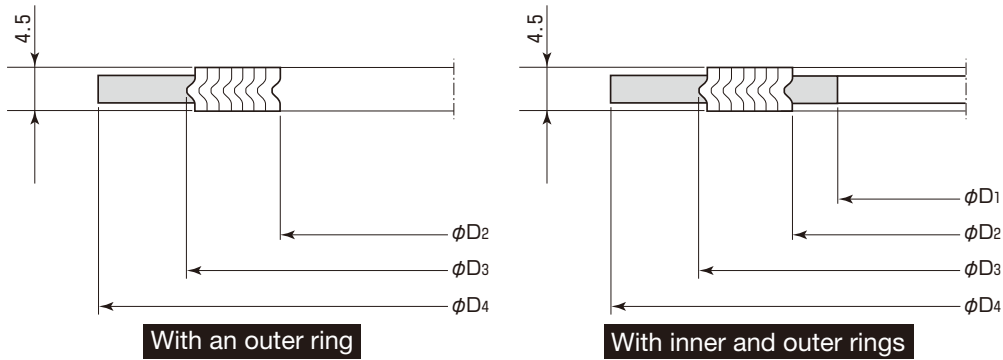

(Unit: mm)

Nominal size		Class 150				Class 300			
		Inner ring inside diameter D <sub>1</sub>	Body inside diameter D <sub>2</sub>	Body outside diameter D <sub>3</sub>	Outer ring outside diameter D <sub>4</sub>	Inner ring inside diameter D <sub>1</sub>	Body inside diameter D <sub>2</sub>	Body outside diameter D <sub>3</sub>	Outer ring outside diameter D <sub>4</sub>
A	B								
650	26	654.0	673.1	698.5	725.4	654.0	673.1	711.2	771.7
700	28	704.8	723.9	749.3	776.2	704.8	723.9	762.0	825.5
750	30	755.6	774.7	800.1	827.0	755.6	774.7	812.8	886.0
800	32	806.4	825.5	850.9	881.1	806.4	825.5	863.6	939.8
850	34	857.2	876.3	908.0	935.0	857.2	876.3	914.4	993.9
900	36	908.0	927.1	958.8	987.6	908.0	927.1	965.2	1047.8
950	38	958.8	974.6	1009.6	1044.7	971.6	1009.6	1047.8	1098.6
1000	40	1009.6	1022.4	1063.8	1095.5	1022.4	1060.4	1098.6	1149.4
1050	42	1060.4	1079.5	1114.6	1146.3	1085.8	1111.2	1149.4	1200.2
1100	44	1111.2	1124.0	1165.4	1197.1	1124.0	1162.0	1200.2	1251.0
1150	46	1162.0	1181.1	1224.0	1255.8	1178.1	1216.2	1254.3	1317.8
1200	48	1212.8	1231.9	1270.0	1306.6	1231.9	1263.6	1311.4	1368.6
(1250)	(50)	1263.6	1282.7	1325.6	1357.4	1267.0	1317.8	1355.9	1419.4
(1300)	(52)	1314.4	1333.5	1376.4	1408.2	1317.8	1368.6	1406.7	1470.2
1350	54	1365.2	1384.3	1422.4	1463.8	1365.2	1403.4	1454.2	1530.4
(1400)	(56)	1422.4	1444.8	1477.8	1514.6	1428.8	1479.6	1524.0	1593.8
(1450)	(58)	1478.0	1500.4	1528.8	1579.6	1484.4	1535.2	1573.3	1655.8
1500	60	1535.2	1557.3	1586.0	1630.4	1557.3	1589.0	1630.4	1706.6

Nominal size		Class 400				Class 600				Class 900			
		Inner ring inside diameter D <sub>1</sub>	Body inside diameter D <sub>2</sub>	Body outside diameter D <sub>3</sub>	Outer ring outside diameter D <sub>4</sub>	Inner ring inside diameter D <sub>1</sub>	Body inside diameter D <sub>2</sub>	Body outside diameter D <sub>3</sub>	Outer ring outside diameter D <sub>4</sub>	Inner ring inside diameter D <sub>1</sub>	Body inside diameter D <sub>2</sub>	Body outside diameter D <sub>3</sub>	Outer ring outside diameter D <sub>4</sub>
A	B												
650	26	654.0	666.8	698.5	746.3	644.7	663.7	714.5	765.3	673.1	692.2	749.3	838.2
700	28	701.8	714.5	749.3	800.1	692.2	704.8	755.6	819.2	723.9	743.0	800.1	901.7
750	30	752.6	765.3	806.4	857.2	752.6	778.0	828.8	879.6	787.4	806.4	857.2	958.8
800	32	800.1	812.8	860.6	911.4	793.8	831.8	882.6	933.4	838.2	863.6	914.4	1016.0
850	34	850.9	866.9	911.4	962.2	850.9	889.0	939.8	997.0	895.4	920.8	971.6	1073.2
900	36	898.7	917.7	965.2	1022.4	901.7	939.8	990.6	1047.8	927.1	946.2	997.0	1124.0

Note 1: The permissible deviations on body thickness is  $4.5^{+0.2}_0$ .

Note 2: It is desirable to use bolts all made of alloy steel (high-strength bolts made of SNB7 or higher grade).

Note 3: Avoid using the nominal sizes enclosed in parentheses wherever possible.

Note 4: We can manufacture PILLAR No. 2300 series and No. 2600 series gaskets with an outer ring, but the use of these gaskets for raised face flanges is not recommended. Please use gaskets with inner and outer rings.

Note 5: Applicable pipe flanges are ANSI B16.47-1996 Series B (formerly API 605) and JPI-7S-43-95 Series B grade butt welding flanges.

Note 6: For metric threads, please consult with us separately.

Note 7: These dimensions are based on JPI-7S-41-2005.

Note 8: The minimum body width of PILLAR No. 2502 and No. 2503 gaskets is 6 mm.

The minimum body width of PILLAR No. 2702 and No. 2703 gaskets is 8 mm.

For gasket body widths smaller than those shown above, please consult with us separately.

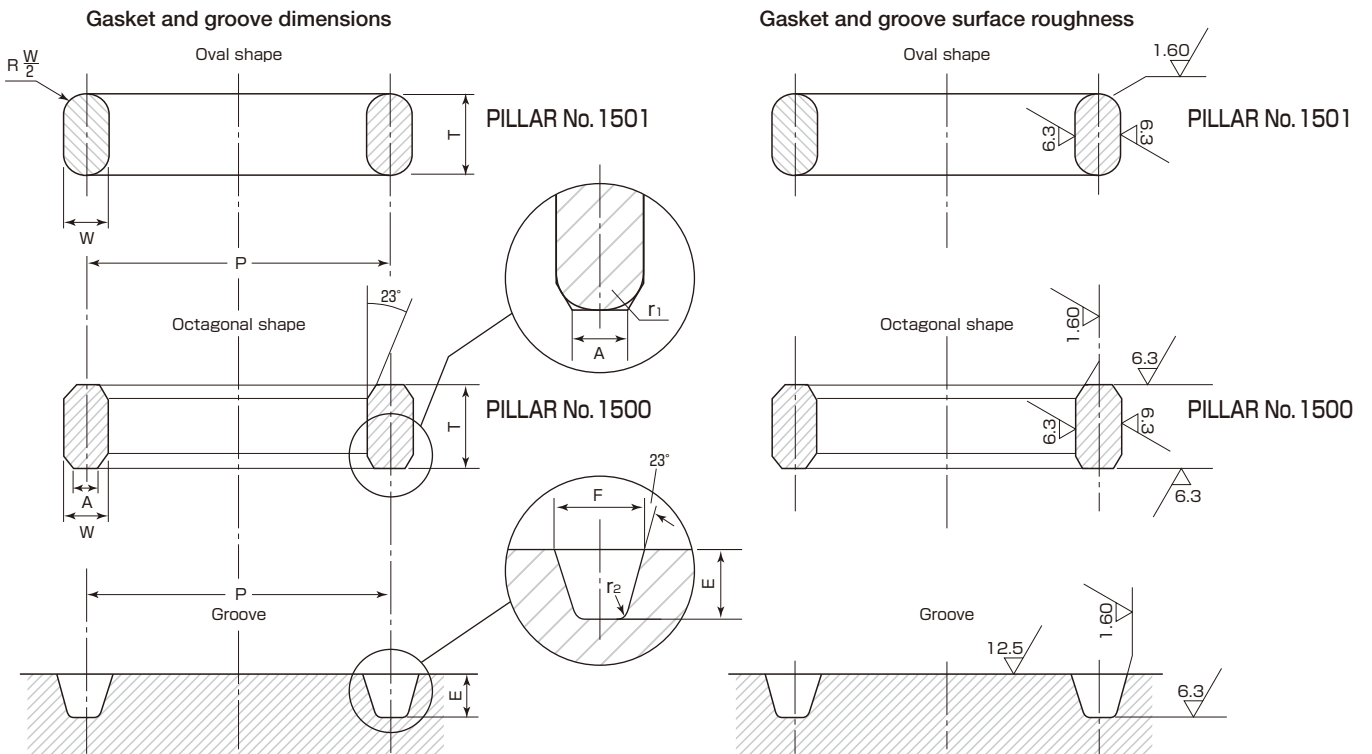

■ Permissible deviations on gasket dimensions

(Unit: mm)

Symbol	Tolerance
P	± 0.18
W	± 0.20
T	± 0.5
A	± 0.20
r <sub>1</sub>	± 0.5
23°	± 0.5°

■ Permissible deviations on groove dimensions

(Unit: mm)

Symbol	Tolerance	
P	± 0.13	
E	± 0.41 0	
F	± 0.20	
r <sub>2</sub>	1.5 or lower	+ 0.8 0
	Over 1.5	± 0.8
23°	± 0.5°	



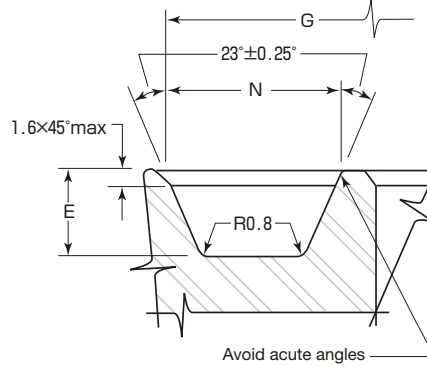
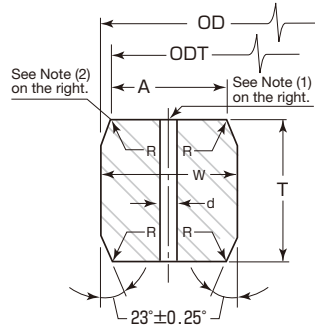

Notes (1) Open a hole (shown in the table below) in one position on the centerline of the gasket.  
 (2) The radius of the corner must be 8% to 12% of the height (T).

(Unit: mm)

Ring number	Applicable flange (Nominal size)								Gasket dimensions					Groove dimensions			
	6BX integral flange						6BX W.N. flange		Outside diameter	Height	Width	Outside diameter of planar section	Width of planar section	Hole diameter	Depth	Outside diameter	Width
	Class 2000	Class 3000	Class 5000	Class 10000	Class 15000	Class 20000	Class 10000	Class 15000 20000	OD +0 -0.15	T +0.20 -0	W +0.20 -0	ODT±0.05	A +0.15 -0	d±0.51	E +0.51 -0	G +0.10 -0	N +0.10 -0
BX150									72.19	9.30	9.30	70.87	7.98	1.5	5.59	73.48	11.43
BX151				1 13/16	1 13/16	1 13/16	1 13/16	1 13/16	76.40	9.63	9.63	75.03	8.26	1.5	5.59	77.77	11.84
BX152				2 1/16	2 1/16	2 1/16	2 1/16	2 1/16	84.68	10.24	10.24	83.24	8.79	1.5	5.84	86.23	12.65
BX153				2 9/16	2 9/16	2 9/16	2 9/16	2 9/16	100.94	11.38	11.38	99.31	9.78	1.5	6.86	102.77	14.07
BX154				3 1/16	3 1/16	3 1/16	3 1/16	3 1/16	116.84	12.40	12.40	115.09	10.64	1.5	7.62	119.00	15.39
BX155				4 1/16	4 1/16	4 1/16	4 1/16	4 1/16	147.96	14.22	14.22	145.95	12.22	1.5	8.38	150.62	17.73
BX156				7 1/16	7 1/16	7 1/16	7 1/16	7 1/16	237.92	18.62	18.62	235.28	15.98	3.0	11.18	241.83	23.39
BX157				9	9	9	9		294.46	20.98	20.98	291.49	18.01	3.0	12.70	299.06	26.39
BX158				11	11	11	11		352.04	23.14	23.14	348.77	19.86	3.0	14.22	357.22	29.18
BX159				13 5/8	13 5/8	13 5/8	13 5/8		426.72	25.70	25.70	423.09	22.07	3.0	15.75	432.64	32.49
BX160			13 5/8						402.59	23.82	13.74	399.21	10.36	3.0	14.22	408.00	19.96
BX161									491.41	28.07	16.20	487.45	12.24	3.0	17.02	497.94	23.62
BX162			16 3/4	16 3/4			16 3/4		475.49	14.22	14.22	473.48	12.22	1.5	8.38	478.33	17.91
BX163			18 3/4						556.16	30.10	17.37	551.89	13.11	3.0	18.29	563.50	25.55
BX164				18 3/4	18 3/4				570.56	30.10	24.59	566.29	20.32	3.0	18.29	577.90	32.77
BX165				21 1/4					624.71	32.03	18.49	620.19	13.97	3.0	19.05	632.56	27.20
BX166				21 1/4					640.03	32.03	26.14	635.51	21.62	3.0	19.05	647.88	34.87
BX167	26 3/4								759.36	35.86	13.11	754.28	8.03	1.5	21.34	768.32	22.91
BX168		26 3/4							765.25	35.86	16.05	760.17	10.97	1.5	21.34	774.22	25.86
BX169				5 1/8			5 1/8		173.51	15.85	12.93	171.27	10.69	1.5	9.65	176.66	16.92
BX170									218.03	14.22	14.22	216.03	12.22	1.5	8.38	220.88	17.91
BX171									267.44	14.22	14.22	265.43	12.22	1.5	8.38	270.28	17.91
BX172									333.07	14.22	14.22	331.06	12.22	1.5	8.38	335.92	17.91
BX303	30	30							852.75	37.95	16.97	847.37	11.61	1.5	22.61	862.30	27.38

Note 1: These dimensions were obtained by converting the values in Table 904.3 in "Specification for Wellhead and Christmas Tree Equipment," API Spec 6A 16th Edition, 1996 into mm.  
 Note 2: Applicable flanges are flanges specified in API Spec 6A 16th Edition, 1996.



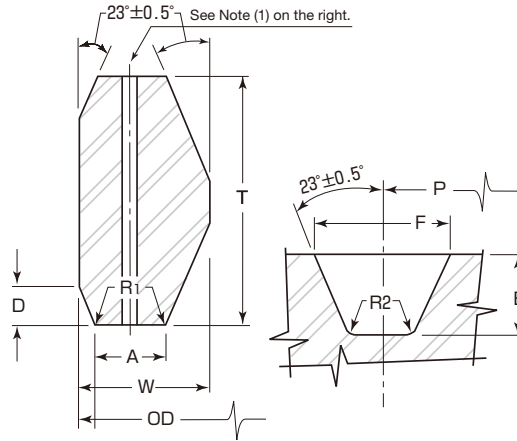

Note (1) For ring numbers RX82 to RX91 only, open a hole in one position on the centerline of Dimension A.

- RX82 to 85:  $\phi 1.5$
- RX86 and 87:  $\phi 2.3$
- RX88 to 91:  $\phi 3.0$

(Unit: mm)

Ring number	Applicable flange (Nominal size)				Gasket dimensions						Groove dimensions			
	6B flange			Segmented flange Class 5000	Outside diameter OD $^{+0}_{-0.15}$	Width W $^{+0.20}_{-0}$	Width of planar section A $^{+0.15}_{-0}$	Height of outside slope D $^{+0}_{-0.76}$	Height T $^{+0.20}_{-0}$	Radius of corner R <sub>1</sub> ±0.51	Depth E $^{+0.51}_{-0}$	Width F ±0.20	Center diameter P ±0.13	Bottom corner radius R <sub>2</sub> (MAX)
	Class 2000	Class 3000	Class 5000											
RX 20				2 1/8	76.20	8.74	4.62	3.18	19.05	1.52	6.35	8.74	68.28	0.76
RX 23	2 1/8				93.27	11.91	6.45	4.24	25.40	1.52	7.87	11.91	82.55	0.76
RX 24		2 1/8	2 1/8		105.97	11.91	6.45	4.24	25.40	1.52	7.87	11.91	95.25	0.76
RX 25				3 1/8	109.55	8.74	4.62	3.18	19.05	1.52	6.35	8.74	101.60	0.76
RX 26	2 3/8				111.91	11.91	6.45	4.24	25.40	1.52	7.87	11.91	101.60	0.76
RX 27		2 3/8	2 3/8		118.26	11.91	6.45	4.24	25.40	1.52	7.87	11.91	107.95	0.76
RX 31	3 1/8	3 1/8			134.54	11.91	6.45	4.24	25.40	1.52	7.87	11.91	123.82	0.76
RX 35			3 1/8		147.24	11.91	6.45	4.24	25.40	1.52	7.87	11.91	136.52	0.76
RX 37	4 1/8	4 1/8			159.94	11.91	6.45	4.24	25.40	1.52	7.87	11.91	149.22	0.76
RX 39			4 1/8		172.64	11.91	6.45	4.24	25.40	1.52	7.87	11.91	161.92	0.76
RX 41	5 1/8	5 1/8			191.69	11.91	6.45	4.24	25.40	1.52	7.87	11.91	180.98	0.76
RX 44			5 1/8		204.39	11.91	6.45	4.24	25.40	1.52	7.87	11.91	193.68	0.76
RX 45	7 1/8	7 1/8			221.84	11.91	6.45	4.24	25.40	1.52	7.87	11.91	211.15	0.76
RX 46			7 1/8		222.25	13.49	6.68	4.78	28.58	1.52	9.65	13.49	211.15	1.52
RX 47					245.26	19.84	10.34	6.88	41.28	2.29	12.70	19.84	228.60	1.52
RX 49	9	9			280.59	11.91	6.45	4.24	25.40	1.52	7.87	11.91	269.88	0.76
RX 50			9		283.36	16.66	8.51	5.28	31.75	1.52	11.18	16.66	269.88	1.52
RX 53	11	11			334.57	11.91	6.45	4.24	25.40	1.52	7.87	11.91	323.85	0.76
RX 54			11		337.34	16.66	8.51	5.28	31.75	1.52	11.18	16.66	323.85	1.52
RX 57	13 5/8	13 5/8			391.72	11.91	6.45	4.24	25.40	1.52	7.87	11.91	381.00	0.76
RX 63					441.73	27.00	14.78	8.46	50.80	2.29	16.00	27.00	419.10	2.29
RX 65	16 3/4				480.62	11.91	6.45	4.24	25.40	1.52	7.87	11.91	469.90	0.76
RX 66		16 3/4			483.39	16.66	8.51	5.28	31.75	1.52	11.18	16.66	469.90	1.52
RX 69					544.12	11.91	6.45	4.24	25.40	1.52	7.87	11.91	533.40	0.76
RX 70					550.06	19.84	10.34	6.88	41.28	2.29	12.70	19.84	533.40	1.52
RX 73	21 1/4				596.11	13.49	6.68	5.28	31.75	1.52	9.65	13.49	584.20	1.52
RX 74		20 3/4			600.86	19.84	10.34	6.88	41.28	2.29	12.70	19.84	584.20	1.52
RX 82					67.87	11.91	6.45	4.24	25.40	1.52	7.87	11.91	57.15	0.76
RX 84					74.22	11.91	6.45	4.24	25.40	1.52	7.87	11.91	63.50	0.76
RX 85					90.09	13.49	6.68	4.24	25.40	1.52	9.65	13.49	79.38	1.52
RX 86					103.58	15.09	8.51	4.78	28.58	1.52	11.18	16.66	90.50	1.52
RX 87					113.11	15.09	8.51	4.78	28.58	1.52	11.18	16.66	100.02	1.52
RX 88					139.29	17.48	10.34	5.28	31.75	1.52	12.70	19.84	123.82	1.52
RX 89					129.77	18.26	10.34	5.28	31.75	1.52	12.70	19.84	114.30	1.52
RX 90					174.62	19.84	12.17	7.42	44.45	2.29	14.22	23.01	155.58	1.52
RX 91					286.94	30.18	19.81	7.54	45.24	2.29	17.53	33.35	260.35	2.29
RX 99					245.67	11.91	6.45	4.24	25.40	1.52	7.87	11.91	234.95	0.76
RX201				1 3/8	51.46	5.74	3.20	1.45	11.30	(2)0.51	4.06	5.56	46.05	0.76
RX205				1 1/8	62.31	5.56	3.05	(1)1.83	11.10	(2)0.51	4.06	5.56	57.15	0.51
RX210				2 3/8	97.64	9.52	5.41	(1)3.18	19.05	(2)0.76	6.35	9.52	88.90	0.76
RX215				4 1/8	140.89	11.91	5.33	(1)4.24	25.40	(2)1.52	7.87	11.91	130.18	0.76

Note 1: The permissible deviations on dimensions are  $^{+0}_{-0.38}$ . Note 2: The permissible deviations on dimensions are  $^{+0.51}_{-0}$ .

Note 3: These dimensions were obtained by converting the values in Table 904.2 in "Specification for Wellhead and Christmas Tree Equipment," API Spec 6A 16th Edition, 1996 into mm.

Note 4: Applicable flanges are flanges specified in API Spec 6A 16th Edition, 1996.

GASKET

Soft gasket

Soft gaskets for JIS-rated pipe flanges

(for flat face flanges, large raised face flanges, small raised face flanges, male-female flanges, and tongue and groove flanges)

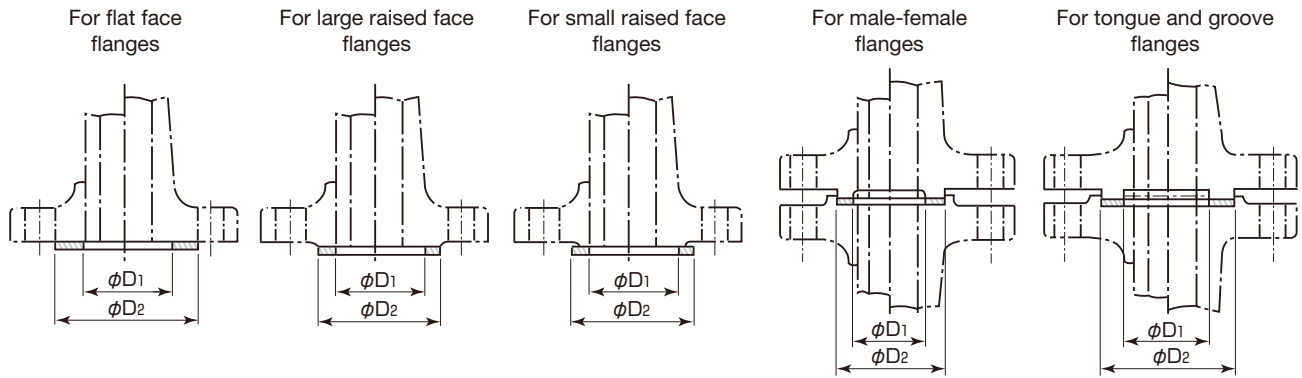

(Unit: mm)

Nominal size	For applicable flanges (flat face flanges, large raised face flanges, and small raised face flanges)										For male-female flanges		For tongue and groove flanges		
	Inside diameter D <sub>1</sub>	Outside diameter D <sub>2</sub>									Inside diameter D <sub>1</sub>	Outside diameter D <sub>2</sub>	Inside diameter D <sub>1</sub>	Outside diameter D <sub>2</sub>	
		2K	5K	10K	Thin flange 10K	16K	20K	30K	40K	63K					
10A	18	—	45	53	55	53	53	59	59	64	18	38	28	38	
15	22	—	50	58	60	58	58	64	64	69	22	42	32	42	
20	28	—	55	63	65	63	63	69	69	75	28	50	38	50	
25	35	—	65	74	78	74	74	79	79	80	35	60	45	60	
32	43	—	78	84	88	84	84	89	89	90	43	70	55	70	
40	49	—	83	89	93	89	89	100	100	108	49	75	60	75	
50	61	—	93	104	108	104	104	114	114	125	61	90	70	90	
65	84	—	118	124	128	124	124	140	140	153	77	110	90	110	
80	90	—	129	134	138	140	140	150	150	163	90	120	100	120	
90	102	—	139	144	148	150	150	163	163	181	102	130	110	130	
100	115	—	149	159	163	165	165	173	183	196	115	145	125	145	
125	141	—	184	190	194	203	203	208	226	235	141	175	150	175	
150	167	—	214	220	224	238	238	251	265	275	167	215	190	215	
175	192	—	240	245	249	—	—	—	—	—	—	—	—	—	—
200	218	—	260	270	274	283	283	296	315	330	218	260	230	260	
225	244	—	285	290	294	—	—	—	—	—	—	—	—	—	—
250	270	—	325	333	335	356	356	360	380	394	270	325	295	325	
300	321	—	370	378	380	406	406	420	434	449	321	375	340	375	
350	359	—	413	423	425	450	450	465	479	488	359	415	380	415	
400	410	—	473	486	488	510	510	524	534	548	410	475	440	475	
450	460	535	533	541	—	575	575	—	—	—	460	523	483	523	
500	513	585	583	596	—	630	630	—	—	—	513	575	535	575	
550	564	643	641	650	—	684	684	—	—	—	564	625	585	625	
600	615	693	691	700	—	734	734	—	—	—	615	675	635	675	
650	667	748	746	750	—	784	805	—	—	—	667	727	682	727	
700	718	798	796	810	—	836	855	—	—	—	718	777	732	777	
750	770	856	850	870	—	896	918	—	—	—	770	832	787	832	
800	820	906	900	920	—	945	978	—	—	—	820	882	837	882	
850	872	956	950	970	—	995	1038	—	—	—	872	934	889	934	
900	923	1006	1000	1020	—	1045	1088	—	—	—	923	987	937	987	
1000	1025	1106	1100	1124	—	1158	—	—	—	—	1025	1092	1042	1092	
1100	1130	1216	1210	1234	—	1258	—	—	—	—	1130	1192	1142	1192	
1200	1230	1326	1320	1344	—	1368	—	—	—	—	1230	1292	1237	1292	
1300	1335	—	—	—	—	1474	—	—	—	—	1335	1392	1337	1392	
1350	1385	1481	1475	1498	—	1534	—	—	—	—	1385	1442	1387	1442	
1400	1435	—	—	—	—	1584	—	—	—	—	1435	1492	1437	1492	
1500	1540	1636	1630	1658	—	1694	—	—	—	—	1540	1592	1537	1592	

Note: These dimensions are based on JIS B 2404:2006. Note, however, that the dimensions for JIS 2K, 40K, and 63K flanges were independently set by PILLAR.

## Soft gasket for JIS-rated pipe flanges

### For flat face (FF) flanges

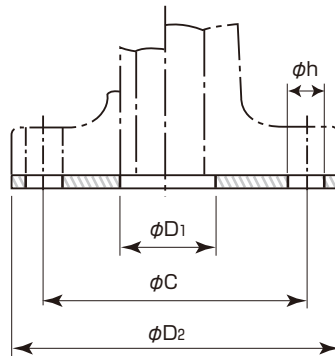

(Unit: mm)

Nominal size	Inside diameter D <sub>1</sub>	2K				5K				10K				16K			
		Outside diameter D <sub>2</sub>	Center circle diameter of bolt hole C	Bolt hole diameter h	Number of bolt holes	Outside diameter D <sub>2</sub>	Center circle diameter of bolt hole C	Bolt hole diameter h	Number of bolt holes	Outside diameter D <sub>2</sub>	Center circle diameter of bolt hole C	Bolt hole diameter h	Number of bolt holes	Outside diameter D <sub>2</sub>	Center circle diameter of bolt hole C	Bolt hole diameter h	Number of bolt holes
10A	18	—	—	—	—	75	55	12	4	90	65	15	4	90	65	15	4
15	22	—	—	—	—	80	60	12	4	95	70	15	4	95	70	15	4
20	28	—	—	—	—	85	65	12	4	100	75	15	4	100	75	15	4
25	35	—	—	—	—	95	75	12	4	125	90	19	4	125	90	19	4
32	43	—	—	—	—	115	90	15	4	135	100	19	4	135	100	19	4
40	49	—	—	—	—	120	95	15	4	140	105	19	4	140	105	19	4
50	61	—	—	—	—	130	105	15	4	155	120	19	4	155	120	19	8
65	84	—	—	—	—	155	130	15	4	175	140	19	4	175	140	19	8
80	90	—	—	—	—	180	145	19	4	185	150	19	8	200	160	23	8
90	102	—	—	—	—	190	155	19	4	195	160	19	8	210	170	23	8
100	115	—	—	—	—	200	165	19	8	210	175	19	8	225	185	23	8
125	141	—	—	—	—	235	200	19	8	250	210	23	8	270	225	25	8
150	167	—	—	—	—	265	230	19	8	280	240	23	8	305	260	25	12
175	192	—	—	—	—	300	260	23	8	305	265	23	12	—	—	—	—
200	218	—	—	—	—	320	280	23	8	330	290	23	12	350	305	25	12
225	244	—	—	—	—	345	305	23	12	350	310	23	12	—	—	—	—
250	270	—	—	—	—	385	345	23	12	400	355	25	12	430	380	27	12
300	321	—	—	—	—	430	390	23	12	445	400	25	16	480	430	27	16
350	359	—	—	—	—	480	435	25	12	490	445	25	16	540	480	33	16
400	410	—	—	—	—	540	495	25	16	560	510	27	16	605	540	33	16
450	460	605	555	23	16	605	555	25	16	620	565	27	20	675	605	33	20
500	513	655	605	23	20	655	605	25	20	675	620	27	20	730	660	33	20
550	564	720	665	25	20	720	665	27	20	745	680	33	20	795	720	39	20
600	615	770	715	25	20	770	715	27	20	795	730	33	24	845	770	39	24
650	667	825	770	25	24	825	770	27	24	845	780	33	24	—	—	—	—
700	718	875	820	25	24	875	820	27	24	905	840	33	24	—	—	—	—
750	770	945	880	27	24	945	880	33	24	970	900	33	24	—	—	—	—
800	820	995	930	27	24	995	930	33	24	1020	950	33	28	—	—	—	—
850	872	1045	980	27	24	1045	980	33	24	1070	1000	33	28	—	—	—	—
900	923	1095	1030	27	24	1095	1030	33	24	1120	1050	33	28	—	—	—	—
1000	1025	1195	1130	27	28	1195	1130	33	28	1235	1160	39	28	—	—	—	—
1100	1130	1305	1240	27	28	1305	1240	33	28	1345	1270	39	28	—	—	—	—
1200	1230	1420	1350	27	32	1420	1350	33	32	1465	1380	39	32	—	—	—	—
1350	1385	1575	1505	27	32	1575	1505	33	32	1630	1540	45	36	—	—	—	—
1500	1540	1730	1660	27	36	1730	1660	33	36	1795	1700	45	40	—	—	—	—

Note: These dimensions are based on JIS B 2404:2006.

Soft gasket for ANSI (JPI) pipe flanges  
For raised face (RF) flanges

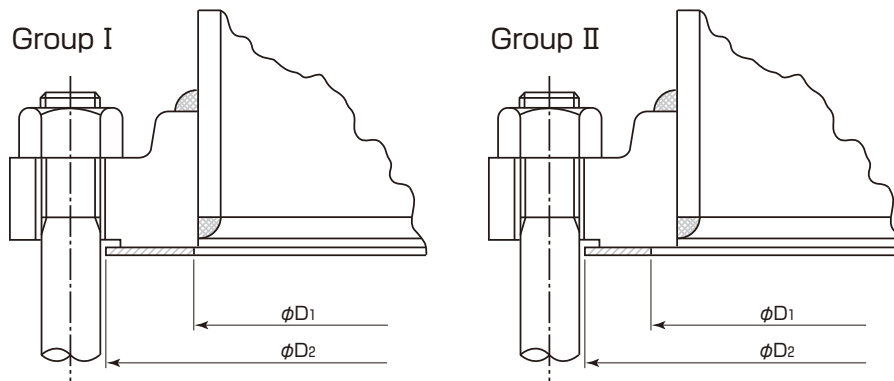

(Unit: mm)

Nominal size		Raised face flange							
		Class 150				Class 300			
		Group I		Group II		Group I		Group II	
A	B	Inside diameter D <sub>1</sub>	Outside diameter D <sub>2</sub>	Inside diameter D <sub>1</sub>	Outside diameter D <sub>2</sub>	Inside diameter D <sub>1</sub>	Outside diameter D <sub>2</sub>	Inside diameter D <sub>1</sub>	Outside diameter D <sub>2</sub>
15	1/2	22	47	25	47	22	53	25	53
20	3/4	28	56	33	56	28	66	33	66
25	1	34	66	38	66	34	72	38	72
(32)	(1 1/4)	44	75	48	75	44	82	48	82
40	1 1/2	49	85	54	85	49	94	54	94
50	2	61	104	73	104	61	110	73	110
65	2 1/2	77	123	86	123	77	129	86	129
80	3	90	135	108	135	90	148	108	148
(90)	(3 1/2)	103	161	121	161	103	164	121	164
100	4	116	173	132	173	116	180	132	180
(125)	(5)	143	196	160	196	143	215	160	215
150	6	169	221	190	221	169	249	190	249
200	8	220	277	238	277	220	306	238	306
250	10	275	338	287	338	275	360	287	360
300	12	326	408	344	408	326	420	344	420
350	14	358	449	376	449	358	484	376	484
400	16	408	512	427	512	408	538	427	538
450	18	459	547	490	547	459	595	490	595
500	20	510	604	535	604	510	651	535	651
600	24	612	715	643	715	612	772	643	772

Note 1: These dimensions are based on JPI-7S-16-98.

Note 2: Avoid using the nominal sizes enclosed in parentheses wherever possible.

Soft gasket for ANSI (JPI) slip-on welding flanges

Nominal size		Class 175		Class 350	
		Inside diameter D <sub>1</sub>	Outside diameter D <sub>2</sub>	Inside diameter D <sub>1</sub>	Outside diameter D <sub>2</sub>
650	26	711	737	724	749
700	28	762	787	775	800
750	30	813	845	826	857
800	32	864	895	876	908
850	34	911	949	927	959
900	36	962	1000	984	1022
950	38	1013	1051	1035	1073
1000	40	1064	1102	1080	1124
1050	42	1118	1162	1130	1181
1100	44	1168	1213	1191	1241
1150	46	1219	1264	1241	1292
1200	48	1270	1314	1292	1343
(1250)	50	1321	1365	—	—
(1300)	52	1372	1422	—	—
1350	54	1422	1473	—	—
1500	60	1575	1626	—	—

Note 1: These dimensions are based on JPI-7S-16-98.

Note 2: Avoid using the nominal sizes enclosed in parentheses wherever possible.

## Soft gasket for ANSI (JPI) pipe flanges For Series A and Series B raised face flanges (Group I)

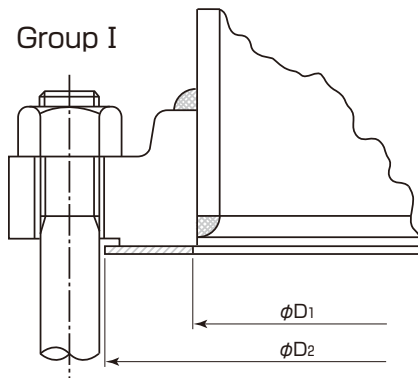

(Unit: mm)

Nominal size		Series A				Series B					
		Class 150		Class 300		Class 75		Class 150		Class 300	
A	B	Inside diameter D <sub>1</sub>	Outside diameter D <sub>2</sub>	Inside diameter D <sub>1</sub>	Outside diameter D <sub>2</sub>	Inside diameter D <sub>1</sub>	Outside diameter D <sub>2</sub>	Inside diameter D <sub>1</sub>	Outside diameter D <sub>2</sub>	Inside diameter D <sub>1</sub>	Outside diameter D <sub>2</sub>
650	26	663	772	663	832	663	705	663	722	663	768
700	28	714	829	714	896	714	756	714	773	714	822
750	30	765	880	765	950	765	807	765	824	765	883
800	32	816	937	816	1003	816	857	816	878	816	937
850	34	867	988	867	1054	867	908	867	932	867	991
900	36	917	1045	917	1115	917	970	917	984	917	1045
950	38	968	1108	968	1051	968	1021	968	1041	968	1096
1000	40	1019	1159	1019	1111	1019	1072	1019	1092	1019	1147
1050	42	1070	1216	1070	1162	1070	1122	1070	1143	1070	1197
1100	44	1121	1273	1121	1216	1121	1178	1121	1194	1121	1248
1150	46	1171	1324	1171	1270	1171	1229	1171	1253	1171	1315
1200	48	1222	1381	1222	1321	1222	1280	1222	1303	1222	1365
(1250)	(50)	1273	1432	1273	1375	1273	1331	1273	1354	1273	1416
(1300)	(52)	1324	1489	1324	1426	1324	1384	1324	1405	1324	1467
1350	54	1375	1546	1375	1489	1375	1435	1375	1461	1375	1527
(1400)	(56)	1425	1602	1425	1540	1425	1493	1425	1511	1425	1591
(1450)	(58)	1476	1659	1476	1591	1476	1543	1476	1577	1476	1651
1500	60	1527	1710	1527	1640	1527	1594	1527	1625	1527	1702

Note 1: These dimensions are based on JPI-7S-16-98.

Note 2: Avoid using the nominal sizes enclosed in parentheses wherever possible.

Soft gasket for ANSI (JPI) pipe flanges  
For flat face (FF) flanges

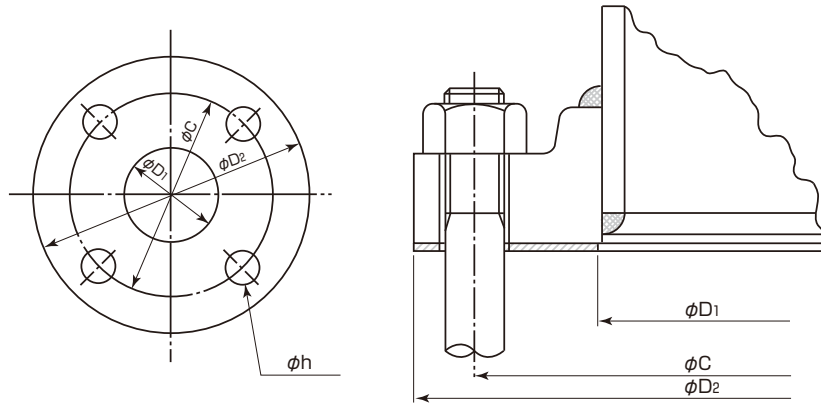

(Unit: mm)

Nominal size		Flat face flange									
		Inside diameter $D_1$	Class 150				Class 300				
A	B		Outside diameter $D_2$	Bolt circle diameter C	Number of bolt holes	Bolt hole diameter h	Outside diameter $D_2$	Bolt circle diameter C	Number of bolt holes	Bolt hole diameter h	
15	$\frac{1}{2}$	22	89	60.5	4	16	95	66.5	4	16	
20	$\frac{3}{4}$	28	99	69.8	4	16	117	82.6	4	19	
25	1	34	108	79.2	4	16	124	88.9	4	19	
(32)	( $1\frac{1}{4}$ )	44	117	88.9	4	16	133	98.6	4	19	
40	$1\frac{1}{2}$	49	127	98.6	4	16	155	114.3	4	22	
50	2	61	152	120.6	4	19	165	127.0	8	19	
65	$2\frac{1}{2}$	77	178	139.7	4	19	190	149.4	8	22	
80	3	90	190	152.4	4	19	210	168.1	8	22	
(90)	( $3\frac{1}{2}$ )	103	216	177.8	8	19	229	184.2	8	22	
100	4	116	229	190.5	8	19	254	200.2	8	22	
(125)	(5)	143	254	215.9	8	22	279	235.0	8	22	
150	6	169	279	241.3	8	22	318	269.7	12	22	
200	8	220	343	298.4	8	22	381	330.2	12	26	
250	10	275	406	362.0	12	26	444	387.4	16	29	
300	12	326	483	431.8	12	26	520	450.8	16	32	
350	14	358	535	476.2	12	29	585	514.4	20	32	
400	16	408	595	539.8	16	29	650	571.5	20	35	
450	18	459	635	577.8	16	32	710	628.6	24	35	
500	20	510	700	635.0	20	32	775	685.8	24	35	
600	24	612	815	749.3	20	35	915	812.8	24	42	

Note 1: These dimensions are based on JPI-7S-16-98.

Note 2: Avoid using the nominal sizes enclosed in parentheses wherever possible.

## Soft gasket for ANSI (JPI) pipe flanges For flat face (FF) flanges (Series A)

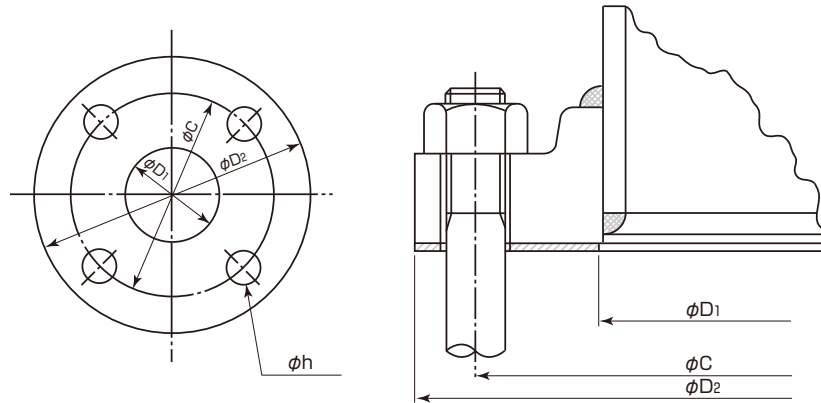

(Unit: mm)

Nominal size		Series A									
		Inside diameter $D_1$	Class 150				Class 300				
A	B		Outside diameter $D_2$	Bolt circle diameter C	Number of bolt holes	Bolt hole diameter h	Outside diameter $D_2$	Bolt circle diameter C	Number of bolt holes	Bolt hole diameter h	
650	26	663	870	806.4	24	35	970	876.3	28	45	
700	28	714	925	863.6	28	35	1035	939.8	28	45	
750	30	765	985	914.4	28	35	1090	997.0	28	48	
800	32	816	1060	977.9	28	42	1150	1054.1	28	51	
850	34	867	1110	1028.7	32	42	1205	1104.9	28	51	
900	36	917	1170	1085.8	32	42	1270	1168.4	32	54	
950	38	968	1240	1149.4	32	42	1170	1092.2	32	42	
1000	40	1019	1290	1200.2	36	42	1240	1155.7	32	45	
1050	42	1070	1345	1257.3	36	42	1290	1206.5	32	45	
1100	44	1121	1405	1314.4	40	42	1355	1263.6	32	48	
1150	46	1171	1455	1365.2	40	42	1415	1320.8	28	51	
1200	48	1222	1510	1422.4	44	42	1465	1371.6	32	51	
(1250)	(50)	1273	1570	1479.6	44	48	1530	1428.8	32	54	
(1300)	(52)	1324	1625	1536.7	44	48	1580	1479.6	32	54	
1350	54	1375	1685	1593.8	44	48	1655	1549.4	28	60	
(1400)	(56)	1425	1745	1651.0	48	48	1710	1600.2	28	60	
(1450)	(58)	1476	1805	1708.2	48	48	1760	1651.0	32	60	
1500	60	1527	1855	1579.0	52	48	1810	1701.8	32	60	

Note 1: These dimensions are based on JPI-7S-16-98.

Note 2: Avoid using the nominal sizes enclosed in parentheses wherever possible.

Soft gasket for ANSI (JPI) pipe flanges  
For flat face (FF) flanges (Series B)

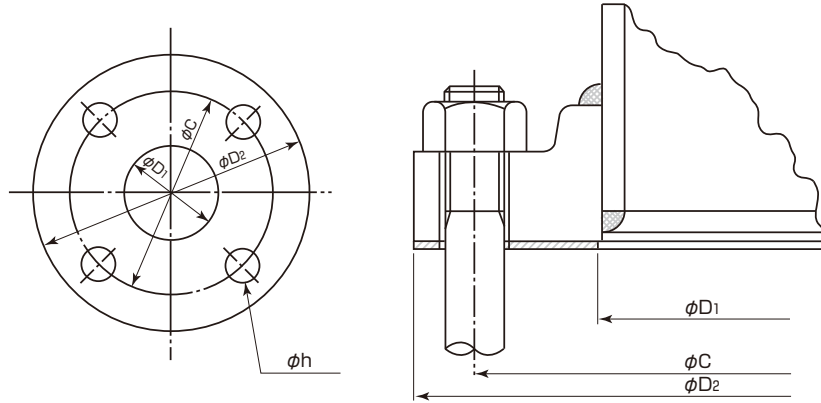

(Unit: mm)

Nominal size		Series B												
		Inside diameter $D_1$	Class 75				Class 150				Class 300			
A	B		Outside diameter $D_2$	Bolt circle diameter C	Number of bolt holes	Bolt hole diameter h	Outside diameter $D_2$	Bolt circle diameter C	Number of bolt holes	Bolt hole diameter h	Outside diameter $D_2$	Bolt circle diameter C	Number of bolt holes	Bolt hole diameter h
650	26	663	760	723.9	36	19	785	744.5	36	22	865	803.1	32	35
700	28	714	815	774.7	40	19	835	795.3	40	22	920	857.2	36	35
750	30	765	865	825.5	44	19	885	846.1	44	22	990	920.8	36	39
800	32	816	915	876.3	48	19	940	900.2	48	22	1055	977.9	32	42
850	34	867	965	927.1	52	19	1005	957.3	40	26	1110	1031.7	36	42
900	36	917	1035	992.1	40	22	1055	1009.6	44	26	1170	1089.2	32	45
950	38	968	1085	1042.9	40	22	1125	1069.8	40	29	1220	1140.0	36	45
1000	40	1019	1135	1093.7	44	22	1175	1120.6	44	29	1275	1190.8	40	45
1050	42	1070	1185	1144.5	48	22	1225	1171.4	48	29	1335	1244.6	36	48
1100	44	1121	1250	1203.4	36	26	1275	1222.2	52	29	1385	1295.4	40	48
1150	46	1171	1300	1254.3	40	26	1340	1284.2	40	32	1460	1365.2	36	51
1200	48	1222	1355	1305.1	44	26	1390	1335.0	44	32	1510	1416.0	40	51
(1250)	(50)	1273	1405	1355.9	44	26	1445	1385.8	48	32	1560	1466.8	44	51
(1300)	(52)	1324	1455	1409.7	48	26	1495	1436.6	52	32	1615	1517.6	48	51
1350	54	1375	1510	1460.5	48	26	1550	1492.2	56	32	1675	1577.8	48	51
(1400)	(56)	1425	1575	1521.0	40	29	1600	1543.0	60	32	1765	1651.0	36	60
(1450)	(58)	1476	1625	1571.8	44	29	1675	1611.4	48	35	1825	1713.0	40	60
1500	60	1527	1675	1622.6	44	29	1725	1662.2	52	35	1880	1763.8	40	60

Note 1: These dimensions are based on JPI-7S-16-98.

Note 2: Avoid using the nominal sizes enclosed in parentheses wherever possible.



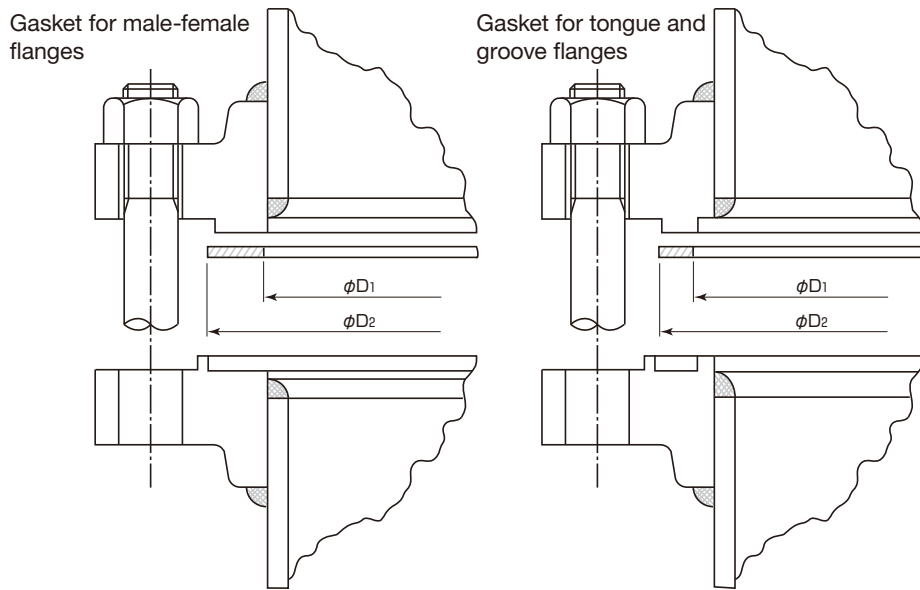

(Unit: mm)

Nominal size		For large male-female flanges				For large tongue and groove flanges	
		Group I		Group II		Group II	
A	B	Inside diameter D <sub>1</sub>	Outside diameter D <sub>2</sub>	Inside diameter D <sub>1</sub>	Outside diameter D <sub>2</sub>	Inside diameter D <sub>1</sub>	Outside diameter D <sub>2</sub>
15	1/2	22	35	25	35	25	35
20	3/4	28	43	33	43	33	43
25	1	34	51	38	51	38	51
(32)	(1 1/4)	44	64	48	64	48	64
40	1 1/2	49	73	54	73	54	73
50	2	61	92	73	92	73	92
65	2 1/2	77	105	86	105	86	105
80	3	90	127	108	127	108	127
(90)	(3 1/2)	103	140	121	140	121	140
100	4	116	157	132	157	132	157
(125)	(5)	143	186	160	186	160	186
150	6	169	216	190	216	190	216
200	8	220	268	238	268	238	268
250	10	275	323	287	323	287	323
300	12	326	380	344	380	344	380
350	14	358	412	376	412	376	412
400	16	408	469	427	469	427	469
450	18	459	532	490	532	490	532
500	20	510	583	535	583	535	583
600	24	612	690	643	690	643	690

Note 1: These dimensions are based on JPI-7S-16-98.

Note 2: Avoid using the nominal sizes enclosed in parentheses wherever possible.

PILLAR No. 4430AF

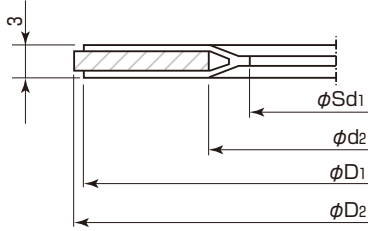

PILLAR No. 4420AF

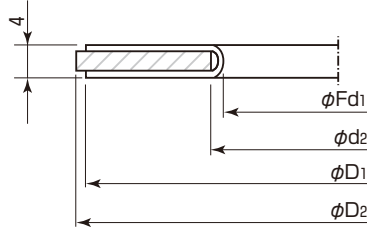

PILLAR No. 4410AF

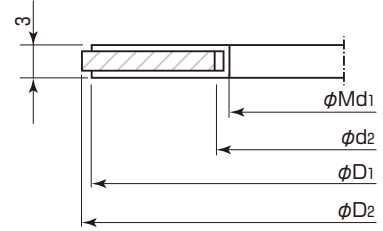

(Unit: mm)

Nominal size	PTFE inside diameter			Soft filler inside diameter d <sub>2</sub>	Nominal pressure: 5K		Nominal pressure: 10K	
	Sd <sub>1</sub>	Fd <sub>1</sub>	Md <sub>1</sub>		PTFE outside diameter D <sub>1</sub>	Soft filler outside diameter D <sub>2</sub>	PTFE outside diameter D <sub>1</sub>	Soft filler outside diameter D <sub>2</sub>
10 A	20	—	26	29	42	45	49	53
15	25	—	31	34	47	50	54	58
20	30	—	36	39	52	55	59	63
25	35	—	41	44	62	65	70	74
32	45	—	51	54	73	78	79	84
40	50	—	56	59	78	83	84	89
50	65	—	71	74	88	93	99	104
65	80	—	86	89	113	118	119	124
80	95	—	101	104	124	129	129	134
(90)	105	—	111	114	134	139	139	144
100	115	—	121	124	144	149	154	159
125	145	—	151	154	179	184	185	190
150	170	—	176	179	209	214	215	220
(175)	200	—	206	209	235	240	240	245
200	225	—	231	234	255	260	265	270
225	250	—	256	259	281	285	286	290
(250)	280	—	286	289	321	325	328	333
300	330	—	336	339	364	370	372	378
350	370	—	376	379	407	413	417	423
400	420	—	426	429	467	473	479	486
450	470	—	476	479	527	533	534	541
500	520	—	526	529	577	583	589	596
(550)	570	575	576	579	634	641	644	650
600	620	625	626	629	684	691	694	700
650	—	675	—	679	—	—	747	750
700	—	730	—	734	—	—	807	810
750	—	780	—	784	—	—	862	870
800	—	830	—	834	—	—	912	920
850	—	880	—	884	—	—	962	970
900	—	930	—	934	—	—	1012	1020
1000	—	1035	—	1039	—	—	1117	1124
1100	—	1135	—	1139	—	—	1227	1234
1200	—	1235	—	1239	—	—	1332	1344
1350	—	1385	—	1389	—	—	1487	1498
1500	—	1540	—	1544	—	—	1642	1658

Note: Avoid using the nominal sizes enclosed in parentheses wherever possible.

PILLAR No. 4431AF

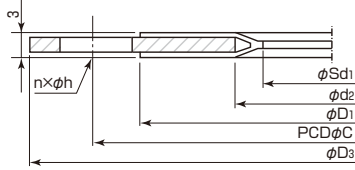

PILLAR No. 4421AF

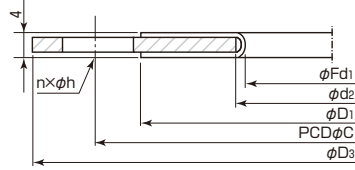

PILLAR No. 4411AF

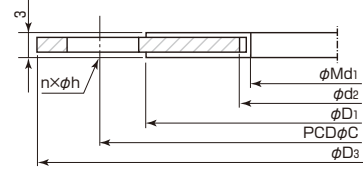

PILLAR No. 4432AF

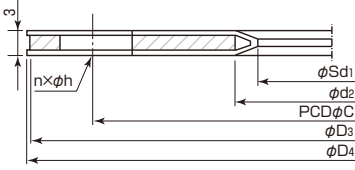

PILLAR No. 4422AF

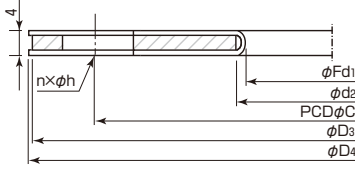

PILLAR No. 4412AF

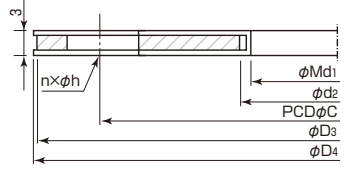

(Unit: mm)

Nominal size	PTFE inside diameter				Soft filler inside diameter	Nominal pressure: 5K						Nominal pressure: 10K						
	Sd <sub>1</sub>		Fd <sub>1</sub>			Md <sub>1</sub>		d <sub>2</sub>	PTFE outside diameter		Soft filler outside diameter	Bolt hole		PTFE outside diameter		Soft filler outside diameter	Bolt hole	
	Sd <sub>1</sub>	Fd <sub>1</sub>	Md <sub>1</sub>	D <sub>1</sub>		D <sub>4</sub>	D <sub>3</sub>		C	n		h	D <sub>1</sub>	D <sub>4</sub>	D <sub>3</sub>		C	n
10 A	20	—	26	29	42	77	75	55	4	12	49	92	90	65	4	15		
15	25	—	31	34	47	82	80	60	4	12	54	97	95	70	4	15		
20	30	—	36	39	52	87	85	65	4	12	59	102	100	75	4	15		
25	35	—	41	44	62	97	95	75	4	12	70	127	125	90	4	19		
32	45	—	51	54	73	117	115	90	4	15	79	137	135	100	4	19		
40	50	—	56	59	78	122	120	95	4	15	84	142	140	105	4	19		
50	65	—	71	74	88	132	130	105	4	15	99	157	155	120	4	19		
65	80	—	86	89	113	157	155	130	4	15	119	177	175	140	4	19		
80	95	—	101	104	124	182	180	145	4	19	129	187	185	150	8	19		
90	105	—	111	114	134	192	190	155	4	19	139	197	195	160	8	19		
100	115	—	121	124	144	202	200	165	8	19	154	212	210	175	8	19		
125	145	—	151	154	179	237	235	200	8	19	185	252	250	210	8	23		
150	170	—	176	179	209	267	265	230	8	19	215	282	280	240	8	23		
175	200	—	206	209	235	302	300	260	8	23	240	307	305	265	12	23		
200	225	—	231	234	255	322	320	280	8	23	265	332	330	290	12	23		
225	250	—	256	259	281	347	345	305	12	23	286	352	350	310	12	23		
250	280	—	286	289	321	387	385	345	12	23	328	402	400	355	12	25		
300	330	—	336	339	364	432	430	390	12	23	372	447	445	400	16	25		
350	370	—	376	379	407	482	480	435	12	25	417	492	490	445	16	25		
400	420	—	426	429	467	542	540	495	16	25	479	562	560	510	16	27		
450	470	—	476	479	527	607	605	555	16	25	534	622	620	565	20	27		
500	520	—	526	529	577	657	655	605	20	25	589	677	675	620	20	27		
550	570	575	576	579	634	722	720	665	20	27	644	747	745	680	20	33		
600	620	625	626	629	684	772	770	715	20	27	694	797	795	730	24	33		
650	—	675	—	679	—	—	—	—	—	—	747	847	845	780	24	33		
700	—	730	—	734	—	—	—	—	—	—	807	907	905	840	24	33		
750	—	780	—	784	—	—	—	—	—	—	862	972	970	900	24	33		
800	—	830	—	834	—	—	—	—	—	—	912	1022	1020	950	28	33		
850	—	880	—	884	—	—	—	—	—	—	962	1072	1070	1000	28	33		
900	—	930	—	934	—	—	—	—	—	—	1012	1122	1120	1050	28	33		
1000	—	1035	—	1039	—	—	—	—	—	—	1117	1237	1235	1160	28	39		
1100	—	1135	—	1139	—	—	—	—	—	—	1227	1347	1345	1270	28	39		
1200	—	1235	—	1239	—	—	—	—	—	—	1332	1467	1465	1380	32	39		
1350	—	1385	—	1389	—	—	—	—	—	—	1487	1632	1630	1540	36	45		
1500	—	1540	—	1544	—	—	—	—	—	—	1642	1797	1795	1770	40	45		

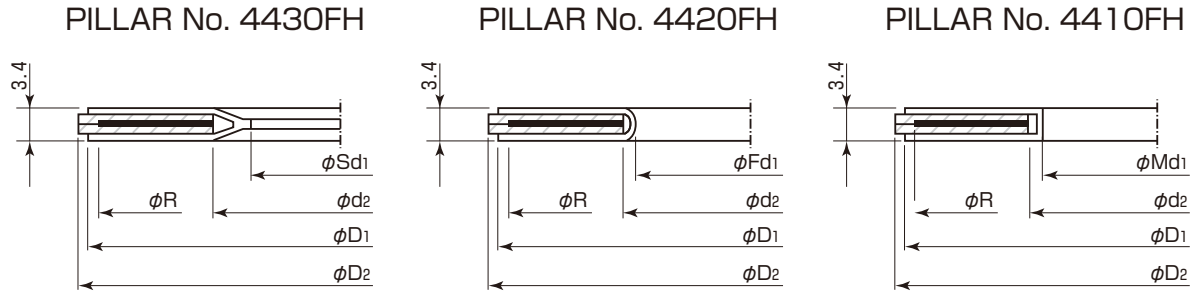

(Unit: mm)

Nominal size	PTFE inside diameter			Soft filler inside diameter d <sub>2</sub>	Nominal pressure: 16K and 20K			Nominal pressure: 30K		
	Sd <sub>1</sub>	Fd <sub>1</sub>	Md <sub>1</sub>		PTFE outside diameter	Soft filler outside diameter	Reinforcing plate outside diameter	PTFE outside diameter	Soft filler outside diameter	Reinforcing plate outside diameter
					D <sub>1</sub>	D <sub>2</sub>	R	D <sub>1</sub>	D <sub>2</sub>	R
10 A	20	—	26	29	49	53	46	55	59	52
15	25	—	31	34	54	58	51	58	64	55
20	30	—	36	39	59	63	56	63	69	60
25	35	—	41	44	70	74	67	73	79	70
32	45	—	51	54	79	84	76	83	89	80
40	50	—	56	59	84	89	81	93	100	90
50	65	—	71	74	99	104	96	108	114	105
65	80	—	86	89	119	124	116	133	140	130
80	95	—	101	104	135	140	132	143	150	140
90	105	—	111	114	148	150	145	153	163	150
100	115	—	121	124	163	165	160	163	173	160
125	145	—	151	154	198	203	195	198	208	195
150	170	—	176	179	233	238	230	238	251	235
200	225	—	231	234	278	283	275	283	296	280
250	280	—	286	289	349	356	345	348	360	345
300	330	—	336	339	399	406	395	408	420	405
350	370	—	376	379	444	450	440	453	465	450
400	420	—	426	429	499	510	495	513	524	510
450	470	—	476	479	564	575	560	—	—	—
500	520	—	526	529	619	630	615	—	—	—
550	570	575	576	579	674	684	670	—	—	—
600	620	625	626	629	724	734	720	—	—	—

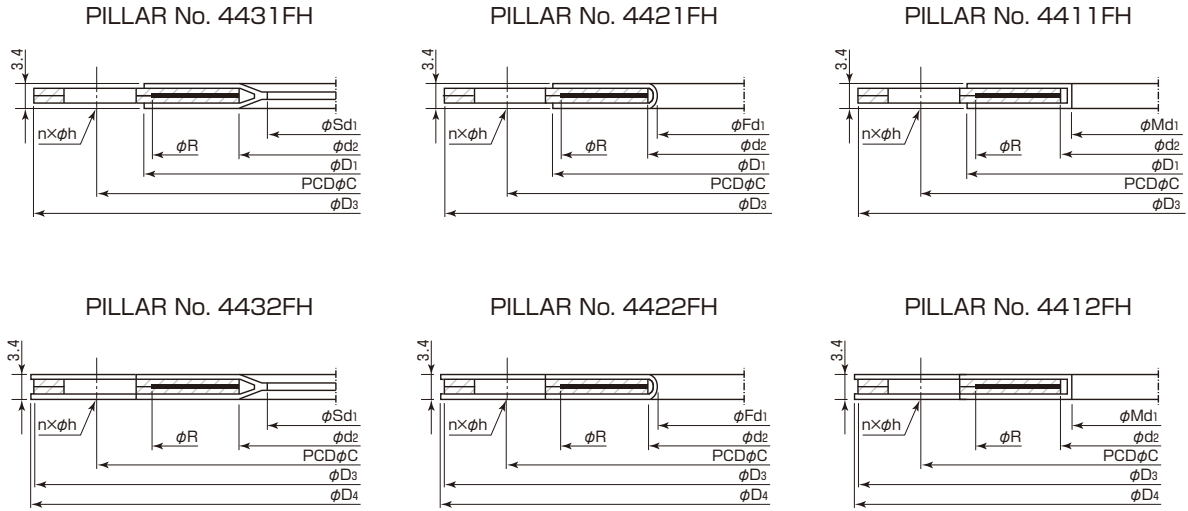

(Unit: mm)

Nominal size	PTFE inside diameter			Soft filler inside diameter	Nominal pressure: 16K and 20K								Nominal pressure: 30K							
	Sd <sub>1</sub>	Fd <sub>1</sub>	Md <sub>1</sub>		d <sub>2</sub>	PTFE outside diameter		Soft filler outside diameter	Reinforcing plate outside diameter	Bolt hole			PTFE outside diameter		Soft filler outside diameter	Reinforcing plate outside diameter	Bolt hole			
						D <sub>1</sub>	D <sub>4</sub>			D <sub>3</sub>	R	C	n	h			D <sub>1</sub>	D <sub>4</sub>	D <sub>3</sub>	R
10 A	20	—	26	29	49	92	90	46	65	4	15	55	112	110	52	75	4	19		
15	25	—	31	34	54	97	95	51	70	4	15	58	117	115	55	80	4	19		
20	30	—	36	39	59	102	100	56	75	4	15	63	122	120	60	85	4	19		
25	35	—	41	44	70	127	125	67	90	4	19	73	132	130	70	95	4	19		
32	45	—	51	54	79	137	135	76	100	4	19	83	142	140	80	105	4	19		
40	50	—	56	59	84	142	140	81	105	4	19	93	162	160	90	120	4	23		
50	65	—	71	74	99	157	155	96	120	8	19	108	167	165	105	130	8	19		
65	80	—	86	89	119	177	175	116	140	8	19	133	202	200	130	160	8	23		
80	95	—	101	104	135	202	200	132	160	8	23	143	212	210	140	170	8	23		
90	105	—	111	114	148	212	210	145	170	8	23	153	232	230	150	185	8	25		
100	115	—	121	124	163	227	225	160	185	8	23	163	242	240	160	195	8	25		
125	145	—	151	154	198	272	270	195	225	8	25	198	277	275	195	230	8	25		
150	170	—	176	179	233	307	305	230	260	12	25	238	327	325	235	275	12	27		
200	225	—	231	234	278	352	350	275	305	12	25	283	372	370	280	320	12	27		
250	280	—	286	289	349	432	430	345	380	12	27	348	452	450	345	390	12	33		
300	330	—	336	339	399	482	480	395	430	16	27	408	517	515	405	450	16	33		
350	370	—	376	379	444	542	540	440	480	16	33	453	562	560	450	495	16	33		
400	420	—	426	429	499	607	605	495	540	16	33	513	632	630	510	560	16	39		
450	470	—	476	479	564	677	675	560	605	20	33	—	—	—	—	—	—	—		
500	520	—	526	529	619	732	730	615	660	20	33	—	—	—	—	—	—	—		
550	570	575	576	579	674	797	795	670	720	20	39	—	—	—	—	—	—	—		
600	620	625	626	629	724	847	845	720	770	24	39	—	—	—	—	—	—	—		

PILLAR No. 4430AF

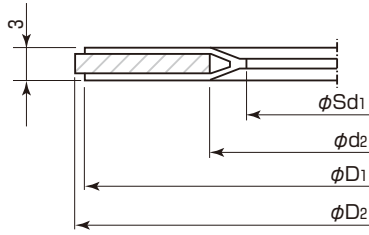

PILLAR No. 4420AF

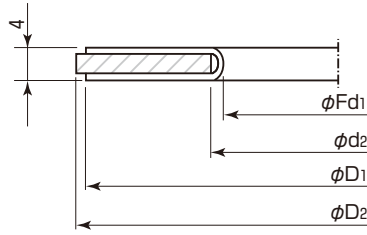

PILLAR No. 4410AF

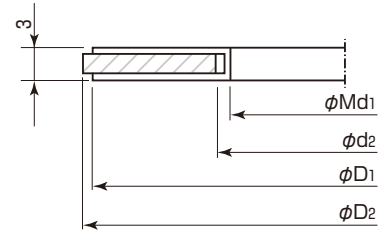

(Unit: mm)

Nominal size	PTFE inside diameter			Soft filler inside diameter d <sub>2</sub>	Class 75		Class 150	
	S <sub>d1</sub>	F <sub>d1</sub>	M <sub>d1</sub>		PTFE outside diameter	Soft filler outside diameter	PTFE outside diameter	Soft filler outside diameter
					D <sub>1</sub>	D <sub>2</sub>	D <sub>1</sub>	D <sub>2</sub>
1/2 B	17	—	21	24	—	—	47	47
3/4	22	—	26	29	—	—	56	56
1	28	—	32	35	—	—	66	66
1 1/4	36	—	40	43	—	—	75	75
1 1/2	42	—	46	49	—	—	85	85
2	53	—	57	60	—	—	92	104
2 1/2	66	—	70	73	—	—	105	123
3	90	—	94	97	—	—	127	135
3 1/2	103	—	107	110	—	—	140	161
4	116	—	120	123	—	—	157	173
5	143	—	147	150	—	—	186	196
6	169	—	173	176	—	—	216	221
8	220	—	224	227	—	—	270	277
10	275	—	279	282	—	—	324	338
12	326	—	330	333	—	—	381	408
14	358	361	362	365	—	—	413	449
16	408	411	412	415	—	—	470	512
18	459	462	463	466	—	—	533	547
20	510	513	514	517	—	—	584	604
24	612	615	616	619	—	—	692	715
26	—	666	—	670	705	705	711	722
28	—	717	—	721	756	756	762	773
30	—	768	—	772	806	807	813	824
32	—	819	—	823	857	857	864	878
34	—	870	—	874	908	908	921	932
36	—	920	—	924	965	970	972	984
38	—	971	—	975	1016	1021	1022	1041
40	—	1022	—	1026	1067	1072	1080	1092
42	—	1073	—	1077	1118	1122	1130	1143
44	—	1124	—	1128	1175	1178	1181	1194
46	—	1174	—	1178	1226	1229	1235	1253
48	—	1225	—	1229	1276	1280	1289	1303
50	—	1276	—	1280	1327	1331	1340	1354
52	—	1327	—	1331	1378	1384	1391	1405
54	—	1378	—	1382	1429	1435	1441	1461
56	—	1428	—	1432	1486	1493	1492	1511
58	—	1479	—	1483	1537	1543	1543	1577
60	—	1530	—	1534	1588	1594	1600	1625

Note: 650A (26B) or greater indicates gaskets for Series B.

PILLAR No. 4431FH

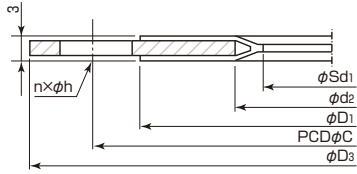

PILLAR No. 4421FH

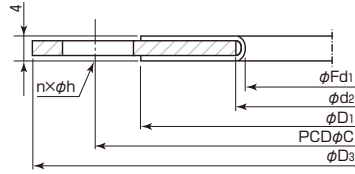

PILLAR No. 4411FH

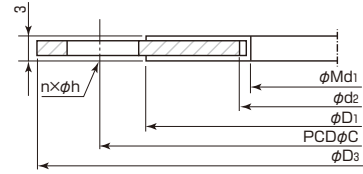

PILLAR No. 4432FH

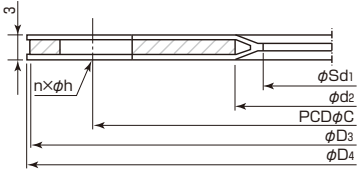

PILLAR No. 4422FH

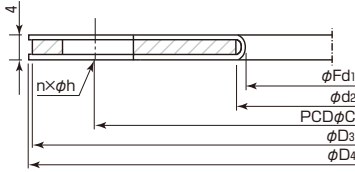

PILLAR No. 4412FH

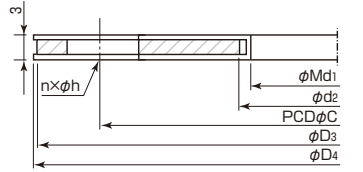

(Unit: mm)

Nominal size	PTFE inside diameter			Soft filler inside diameter	Class 75						Class 150					
	Sd <sub>1</sub>	Fd <sub>1</sub>	Md <sub>1</sub>		d <sub>2</sub>	PTFE outside diameter		Soft filler outside diameter	Bolt hole		D <sub>1</sub>	D <sub>4</sub>	D <sub>3</sub>	C	Bolt hole	
						D <sub>1</sub>	D <sub>4</sub>		n	h					n	h
1/2 B	17	—	21	24	—	—	—	—	—	—	47	91	89	60.5	4	16
3/4	22	—	26	29	—	—	—	—	—	—	56	101	99	69.8	4	16
1	28	—	32	35	—	—	—	—	—	—	66	110	108	79.2	4	16
1 1/4	36	—	40	43	—	—	—	—	—	—	75	119	117	88.9	4	16
1 1/2	42	—	46	49	—	—	—	—	—	—	85	129	127	98.6	4	16
2	53	—	57	60	—	—	—	—	—	—	92	154	152	120.6	4	19
2 1/2	66	—	70	73	—	—	—	—	—	—	105	180	178	139.7	4	19
3	90	—	94	97	—	—	—	—	—	—	127	192	190	152.4	4	19
3 1/2	103	—	107	110	—	—	—	—	—	—	140	218	216	177.8	8	19
4	116	—	120	123	—	—	—	—	—	—	157	231	229	190.5	8	19
5	143	—	147	150	—	—	—	—	—	—	186	256	254	215.9	8	22
6	169	—	173	176	—	—	—	—	—	—	216	281	279	241.3	8	22
8	220	—	224	227	—	—	—	—	—	—	270	345	343	298.4	8	22
10	275	—	279	282	—	—	—	—	—	—	324	408	406	362.0	12	26
12	326	—	330	333	—	—	—	—	—	—	381	485	483	431.8	12	26
14	358	361	362	365	—	—	—	—	—	—	413	537	535	476.2	12	29
16	408	411	412	415	—	—	—	—	—	—	470	597	595	539.8	16	29
18	459	462	463	466	—	—	—	—	—	—	533	637	635	577.8	16	32
20	510	513	514	517	—	—	—	—	—	—	584	702	700	635.0	20	32
24	612	615	616	619	—	—	—	—	—	—	692	817	815	749.3	20	35
26	—	666	—	670	705	762	760	723.9	36	19	711	—	785	744.5	36	22
28	—	717	—	721	756	817	815	774.7	40	19	762	—	835	795.3	40	22
30	—	768	—	772	806	867	865	825.5	44	19	813	—	885	846.1	44	22
32	—	819	—	823	857	917	915	876.3	48	19	868	—	940	900.2	48	22
34	—	870	—	874	908	967	965	927.1	52	19	921	—	1005	957.3	40	26
36	—	920	—	924	965	1037	1035	992.1	40	22	972	—	1055	1009.6	44	26
38	—	971	—	975	1016	1087	1085	1042.9	40	22	1022	—	1125	1069.8	40	29
40	—	1022	—	1026	1067	1137	1135	1093.7	44	22	1080	—	1175	1120.6	44	29
42	—	1073	—	1077	1118	1187	1185	1144.5	48	22	1130	—	1225	1171.4	48	29
44	—	1124	—	1128	1175	1252	1250	1203.4	36	26	1181	—	1275	1222.2	52	29
46	—	1174	—	1178	1226	1302	1300	1254.3	40	26	1235	—	1340	1284.2	40	32
48	—	1225	—	1229	1276	1357	1355	1305.1	44	26	1289	—	1390	1335.0	44	32
50	—	1276	—	1280	1327	1407	1405	1355.9	44	26	1340	—	1445	1385.8	48	32
52	—	1327	—	1331	1378	1457	1455	1409.7	48	26	1391	—	1495	1436.6	52	32
54	—	1378	—	1382	1429	1512	1510	1460.5	48	26	1441	—	1550	1492.2	56	32
56	—	1428	—	1432	1486	1577	1575	1521.0	40	29	1492	—	1600	1543.0	60	32
58	—	1479	—	1483	1537	1627	1625	1571.8	44	29	1543	—	1675	1611.4	48	35
60	—	1530	—	1534	1588	1677	1675	1622.6	44	29	1600	—	1725	1662.2	52	35

Note: 650A (26B) or greater indicates gaskets for Series B.

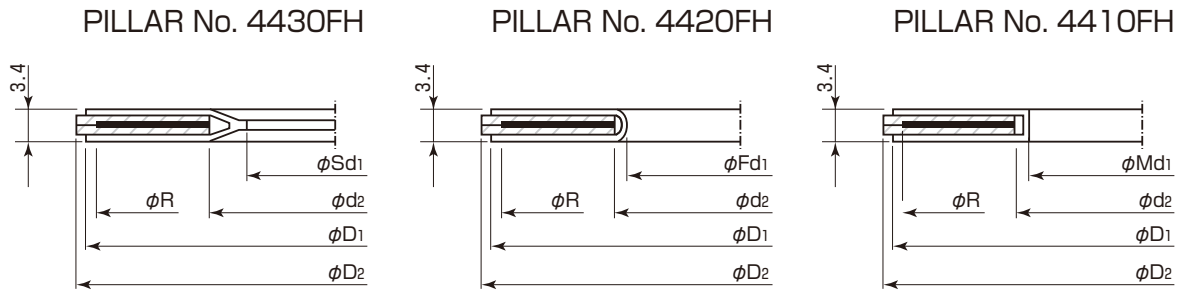

(Unit: mm)

Nominal size	PTFE inside diameter			Soft filler inside diameter	PTFE outside diameter	Soft filler outside diameter	Reinforcing plate outside diameter
	Sd <sub>1</sub>	Fd <sub>1</sub>	Md <sub>1</sub>	d <sub>2</sub>	D <sub>1</sub>	D <sub>2</sub>	R
1/2B	17	—	21	24	53	53	35
3/4	22	—	26	29	66	66	43
1	28	—	32	35	72	72	51
1 1/4	36	—	40	43	82	82	64
1 1/2	42	—	46	49	94	94	73
2	53	—	57	60	92	110	92
2 1/2	66	—	70	73	105	129	105
3	90	—	94	97	127	148	127
3 1/2	103	—	107	110	140	164	140
4	116	—	120	123	157	180	157
5	143	—	147	150	186	215	186
6	169	—	173	176	216	249	216
8	220	—	224	227	270	306	270
10	275	—	279	282	324	360	324
12	326	—	330	333	381	420	381
14	358	361	362	365	413	484	413
16	408	411	412	415	470	538	470
18	459	462	463	466	533	595	533
20	510	513	514	517	584	651	584
24	612	615	616	619	692	772	692
26	—	666	—	670	737	768	737
28	—	717	—	721	787	822	787
30	—	768	—	772	845	883	845
32	—	819	—	823	902	937	902
34	—	870	—	874	952	991	952
36	—	920	—	924	1010	1045	1010
38	—	971	—	975	1060	1096	1060
40	—	1022	—	1026	1115	1147	1115
42	—	1073	—	1077	1168	1197	1168
44	—	1124	—	1128	1219	1248	1219
46	—	1174	—	1178	1270	1315	1270
48	—	1225	—	1229	1327	1365	1327
50	—	1276	—	1280	1387	1416	1378
52	—	1327	—	1331	1429	1467	1429
54	—	1378	—	1382	1480	1527	1480
56	—	1428	—	1432	1537	1591	1537
58	—	1479	—	1483	1594	1651	1594
60	—	1530	—	1534	1651	1702	1651

Note: 650A (26B) or greater indicates gaskets for Series B.



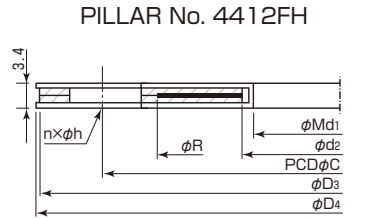
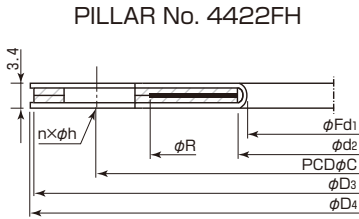
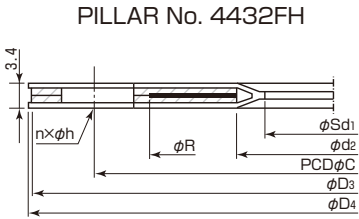
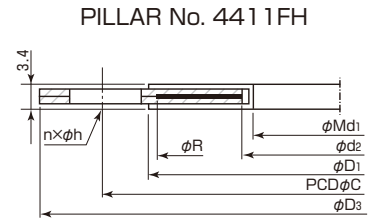
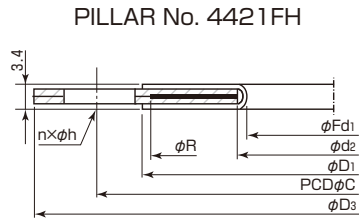
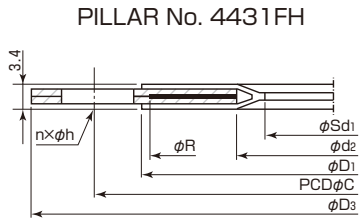

(Unit: mm)

Nominal size	PTFE inside diameter			Soft filler inside diameter	PTFE outside diameter		Soft filler outside diameter	Reinforcing plate outside diameter	Bolt hole		
	Sd <sub>1</sub>	Fd <sub>1</sub>	Md <sub>1</sub>	d <sub>2</sub>	D <sub>1</sub>	D <sub>4</sub>	D <sub>3</sub>	R	C	n	h
1/2B	17	—	21	24	53	97	95	35	66.5	4	16
1/4	22	—	26	29	66	119	117	43	82.6	4	19
1	28	—	32	35	72	126	124	51	88.9	4	19
1 1/4	36	—	40	43	82	135	133	64	98.6	4	19
1 1/2	42	—	46	49	94	157	155	73	114.3	4	22
2	53	—	57	60	92	167	165	92	127.0	8	19
2 1/2	66	—	70	73	105	192	190	105	149.4	8	22
3	90	—	94	97	127	212	210	127	168.1	8	22
3 1/2	103	—	107	110	140	231	229	140	184.2	8	22
4	116	—	120	123	157	256	254	157	200.2	8	22
5	143	—	147	150	186	281	279	186	235.0	8	22
6	169	—	173	176	216	320	318	216	269.7	12	22
8	220	—	224	227	270	383	381	270	330.2	12	26
10	275	—	279	282	324	446	444	324	387.4	16	29
12	326	—	330	333	381	522	520	381	450.8	16	32
14	358	361	362	365	413	587	585	413	514.4	20	32
16	408	411	412	415	470	652	650	470	571.5	20	35
18	459	462	463	466	533	712	710	533	628.6	24	35
20	510	513	514	517	584	777	775	584	685.8	24	35
24	612	615	616	619	692	917	915	692	812.8	24	42
26	—	666	—	670	737	—	865	737	803.1	32	35
28	—	717	—	721	787	—	920	787	857.2	36	35
30	—	768	—	772	845	—	990	845	920.8	36	39
32	—	819	—	823	902	—	1055	902	977.9	32	42
34	—	870	—	874	952	—	1110	952	1031.7	36	42
36	—	920	—	924	1010	—	1170	1010	1089.2	32	45
38	—	971	—	975	1060	—	1220	1060	1140.0	36	45
40	—	1022	—	1026	1115	—	1275	1115	1190.8	40	45
42	—	1073	—	1077	1168	—	1335	1168	1244.6	36	48
44	—	1124	—	1128	1219	—	1385	1219	1295.4	40	48
46	—	1174	—	1178	1270	—	1460	1270	1365.2	36	51
48	—	1225	—	1229	1327	—	1510	1327	1416.0	40	51
50	—	1276	—	1280	1378	—	1560	1378	1466.8	44	51
52	—	1327	—	1331	1429	—	1615	1429	1517.6	48	51
54	—	1378	—	1382	1480	—	1675	1480	1577.8	48	51
56	—	1428	—	1432	1537	—	1765	1537	1651.0	36	60
58	—	1479	—	1483	1594	—	1825	1594	1713.0	40	60
60	—	1530	—	1534	1651	—	1880	1651	1763.8	40	60

Note: 650A (26B) or greater indicates gaskets for Series B.



**PILLAR** PILLAR Corporation  
CLEAN SAFETY FRONTIER

Head office/Sales Headquarters  
7-1, Shinmachi 1-chome, Nishi-ku, Osaka 550-0013, Japan  
Phone: +81-6-7166-8326 Fax: +81-6-7166-8514

Email : [sales@pillar.co.jp](mailto:sales@pillar.co.jp)

<https://www3.pillar.co.jp/en/product/>



**Safety  
precaution**

● When using this product, please use correctly and pay sufficient attention to safety.

\* Please understand that this catalog may change without prior notice.  
\* The values shown on this catalog are reference values, not guaranteed values.